



Cyprus
University of
Technology

EEN452 - Control and Operation of Electric Power Systems

Part 1: Revision of power engineering fundamentals

<https://sps.cut.ac.cy/courses/een452/>

Dr Petros Aristidou

Department of Electrical Engineering, Computer Engineering & Informatics

Last updated: January 24, 2023

This course extends the into the area of electric power systems based on the courses EEN320 and EEN442. In the first part, it analyzes the dynamic behavior and various control structures. In the second part, it focuses advanced concepts and operational principles concerning economic and secure operation of electric power systems.

Learning outcomes

On completion of this course, students should be able to:

- Describe and analyze the control structures for stable operation of electric power systems;
- Perform system-wide studies to identify and propose solutions for common dynamic problems; and,
- Understand, describe, and analyze the economic and secure operation of electric power systems.

The following course knowledge are prerequisites for this course:

- 1 Engineering mathematics (advanced mathematics I-III, linear algebra)
- 2 Electric circuit analysis I-II
- 3 Power systems I (EEN320)
- 4 Power systems II (EEN442)

The course consists of these parts:

- 1 Revision of power engineering fundamentals (per-unit, models of lines, transformers, generators and loads, power-flow analysis)
- 2 Synchronous machine dynamic model
- 3 Frequency control (turbine-generation, primary/secondary frequency control, inertia)
- 4 Voltage control (Volt-Var control, primary voltage control, AVR, shunt devices, tap-changing transformers, FACTS devices)
- 5 Power system stability (angle/voltage/frequency, small-disturbance, transient stability)
- 6 Economics of electricity generation (economic dispatch, unit commitment, basic market operations)
- 7 Optimal and secure operation (power system states, optimal power flow)

- 1 A. Gómez-Expósito, A. J. Conejo, and C. A. Canizares, *Electric Energy Systems Analysis and Operation*, 2nd edition, CRC Press, 2018.
- 2 D. Glover, M. S. Sarma and T. Overbye, *Power System Analysis & Design*, 6th edition, Cengage Learning, 2017.
- 3 A. J. Wood, B. F. Wollenberg and G. B. Sheble, *Power generation, operation, and control*, 3rd edition, Wiley-IEEE Press, 2014.
- 4 Ν. Βοβός, Γ. Γιαννακόπουλος, “Έλεγχος και ευστάθεια συστημάτων ηλεκτρικής ενέργειας”, εκδόσεις ΖΗΤΗ, 2008

Due to special circumstances, this year the course is following a blended learning schedule with online teaching, small videos, and mini-projects. This might be modified according to the requirements and the regulations.

- ① Theory delivered through lectures (in class \approx 28 hours)
- ② Practical examples (in class \approx 12 hours)
- ③ Hardware laboratory work (in class \approx 4 hours)
 - ⓐ Synchronous Motors/Generators

- 1 Assignments (software-based) (25%)
- 2 Mini project (literature-based) (25%)
- 3 Final written exam (50%)
- 4 Homework exercises (5% bonus only if they change the final score)

After this part of the lecture and additional reading, you should be able to . . .

- 1 . . . describe the basic operation of power systems;
- 2 . . . use the per-unit system to perform analysis of power systems;
- 3 . . . describe and use the models used for the basic power system components (line/transformer/generator/load models);
- 4 . . . describe and use the power-flow solution.

1 Outline

- 1 **Basics**
 - Electric power system overview
 - Phasors in electrical power systems
 - Three-phase power
 - Per-unit
- 2 Transmission lines
- 3 Power transformers
- 4 Rotating machines
- 5 Electric loads
- 6 Power-flow problem

1.1 Electric power system overview

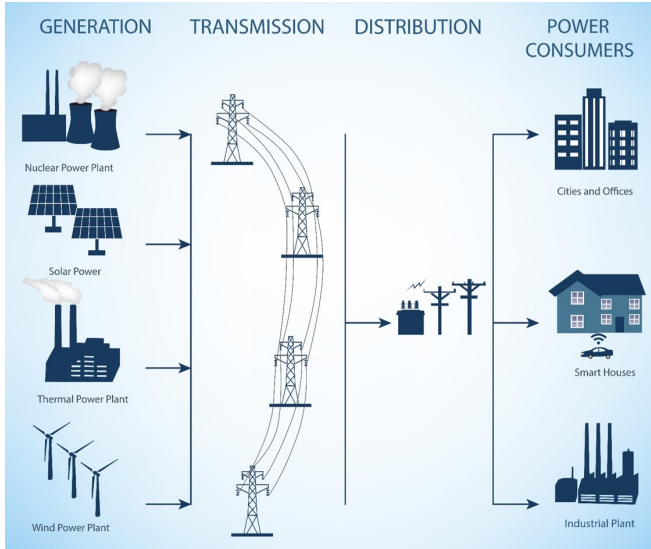

- Often, economic, geographic, environmental or technological reasons impede generation of *all* demand closed to load centres (cities, industrial sites)
- Therefore, large share of electric power is generated far away from load centres
- Need (electric) infrastructure to transport electricity from generators to loads
- This infrastructure is called a power network
- Fundamental components of a power network are
 - Conductors/power lines to transport electric current (overhead lines and cables)
 - Power transformers to modify voltage levels between different network parts
 - Protection equipment to disconnect (some) parts of a network in case of a failure

- Optimal economic interconnection of different generators / end-users / networks mainly depends on
 - Distance
 - Amount of power to be transmitted
- Consequently, most power systems worldwide consist of
 - **Transmission network:** *global* power network over large distances; works at high voltages
 - **Distribution network:** *local* electricity network to deliver power to end-users; works at medium and low voltage
 - Voltage usually transformed several times to lower values the closer to end-user
 - These voltage transformations are performed in **substations**
 - Above low voltage (LV) level, power transfer is usually three-phase

1.1 Electric power systems - Standard structure (1)

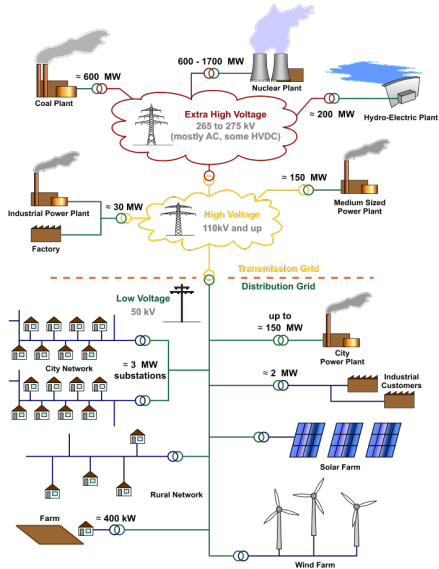

©MBizon

1.1 Electric power systems - Standard structure (2)

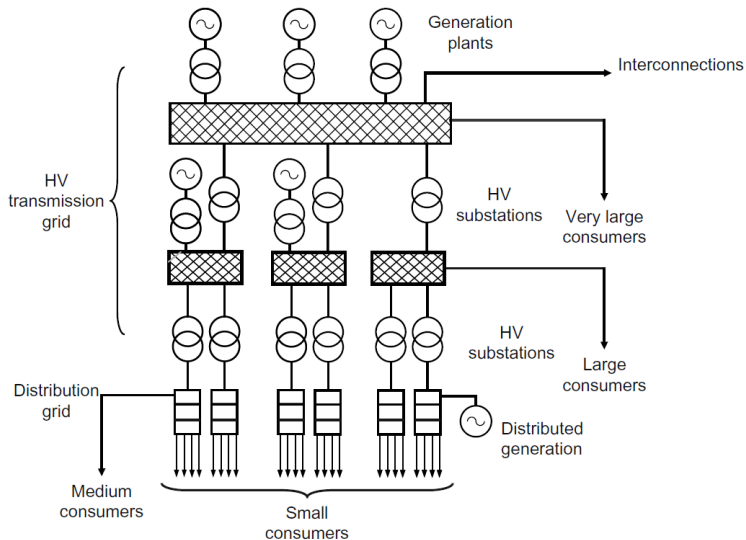

Source: J. Machowski et al, "Power system dynamics: stability and control", John Wiley & Sons, 2011

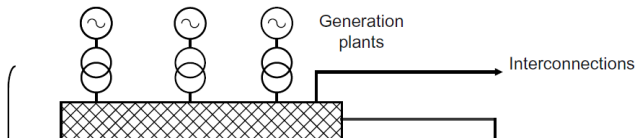

Characteristics

- Few, very large generators 1 - 1,000 MW (coal, nuclear, gas, hydro)
- Large generators connected to HV transmission system
- Role of HV transmission system: bulk power transport from generators to load centers (e.g. cities)
- Close to load centers, voltage transformation to lower levels in distribution network
- Unidirectional flow from HV to LV

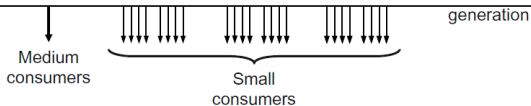

Source: J. Machowski et al, "Power system dynamics: stability and control", John Wiley & Sons, 2011

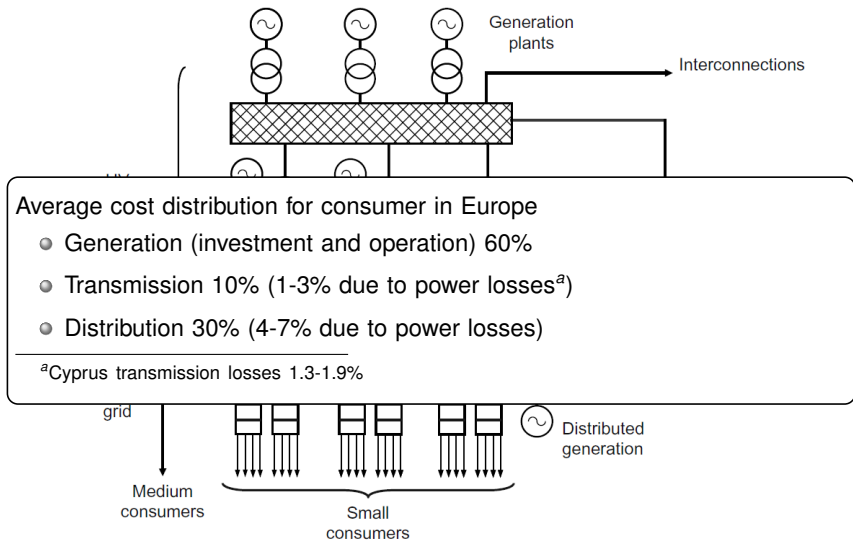

Source: J. Machowski et al, "Power system dynamics: stability and control", John Wiley & Sons, 2011

Country	high voltage (HV)	medium voltage (MV)	low voltage (LV)
UK	400 kV (275 kV)	132 kV - 11 kV	400 / 230 V
Germany	380 kV	110 - 10 kV	400 / 230 V
US	765 - 345 kV	230 - 4 kV	480 / 120 V
Nigeria	330 - 132 kV	33-10 kV	415/240 V
Cyprus	132 - 66 kV	22-11 kV	400/230 V

- The above voltage magnitudes refer to the line-to-line voltage V_{LL} of the corresponding three-phase system
- The line-to-ground voltage V_{LG} is given by $V_{LL} = \sqrt{3}V_{LG}$

1.1 Example of Cyprus

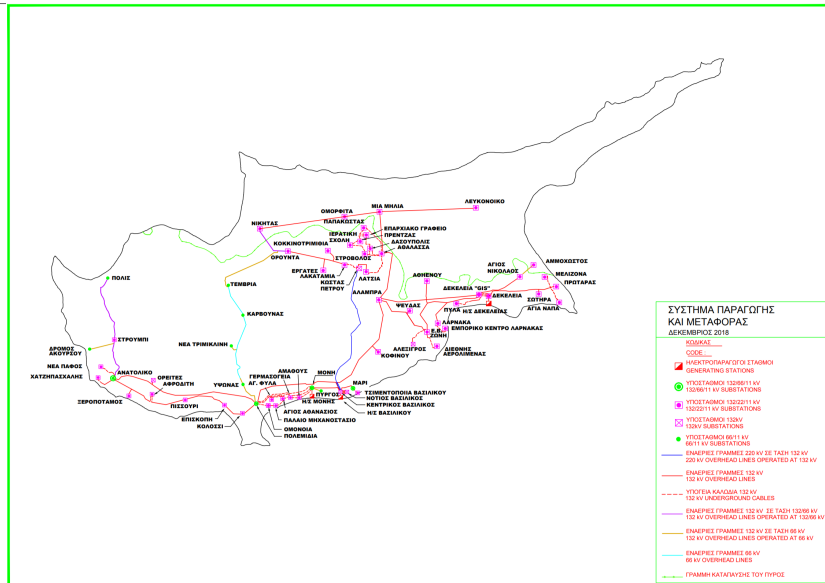

Source: <https://www.dsm.org.cy/>

- Sinusoidal waveforms can also be represented by *phasors* in the complex plane
- Phasors are very popular in electric power systems
- Main reasons: simplify visualisation and calculation of electrical networks
- This is very useful for analysis, design and operation of power systems

- Consider

$$x(t) = \hat{X} \cos(\omega t + \theta)$$

- Via Euler's Formula, we define the phasor corresponding to $x(t)$ as¹

$$\underline{X} = \frac{\hat{X}}{\sqrt{2}} (\cos(\theta) + j \sin(\theta)) = \underbrace{X (\cos(\theta) + j \sin(\theta))}_{\text{trigonometric form}} = \underbrace{X e^{j\theta}}_{\text{exponential form}}$$

- Then

$$x(t) = \sqrt{2} \Re\{\underline{X} e^{j\omega t}\},$$

i.e., momentary value of $x(t)$ corresponds to real part of the phasor \underline{X} rotating at angular speed ω

- Alternative common notation for a phasor

$$\underline{X} = X e^{j\theta} = \underbrace{X/\theta}_{\text{angular form}}$$

¹Here j denotes the imaginary unit.

- Phasors of voltage and current

$$\underline{V} = V (\cos(\varphi_v) + j \sin(\varphi_v)) = V e^{j\varphi_v} = V \underline{\angle\varphi_v}$$

$$\underline{I} = I (\cos(\varphi_i) + j \sin(\varphi_i)) = I e^{j\varphi_i} = I \underline{\angle\varphi_i}$$

$$\varphi = \varphi_v - \varphi_i$$

- Note: as we have assumed stationary conditions, it suffices to use \underline{X} to describe $x(t)$ for network calculations

Why? Because the term $e^{j\omega t}$ cancels out, whenever multiplying two complex quantities

$$\left(\underline{V} e^{j\omega t}\right) \left(\underline{I} e^{j\omega t}\right)^* = \underline{V} \underline{I}^* e^{j\omega t} e^{-j\omega t} = \underline{V} \underline{I}^*,$$

where the operator $*$ denotes complex conjugation

1.2 Visualization of a phasor

$$\underline{V} = Ve^{j\theta} = \underbrace{V/\theta}_{\text{angular form}}$$

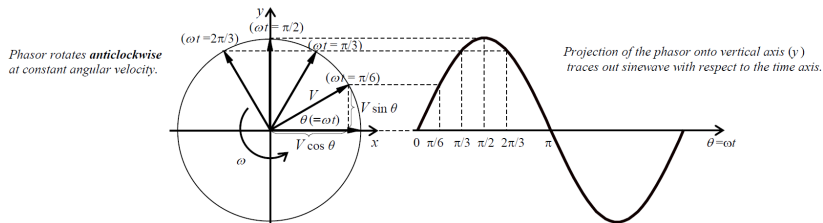

©J. Corda

- starting from the origin $0 + j0$
- projection on the real axis is $\frac{1}{\sqrt{2}}v(t)$
- the phasor is the position at $t = 0$ of the rotating vector

- Phasor diagrams (φασικά διαγράμματα): A graphical representation of the phasors

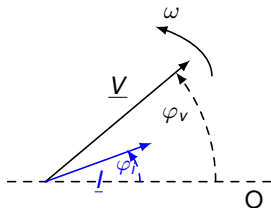

- Now, we can introduce a third important quantity in power systems - the complex apparent power

$$\underline{S} = \underline{V}\underline{I}^* = VIe^{j(\varphi_v - \varphi_i)} = VIe^{j\varphi} = VI(\cos(\varphi) + j\sin(\varphi))$$

- Remember that $\varphi = \varphi_v - \varphi_i$ is called the power factor angle and it's connected to power factor as $PF = \cos\varphi$
- The absolute value of the complex apparent power is called apparent power S

$$S = |\underline{S}| = VI$$

- The unit of \underline{S} and S is Volt-Ampere [VA]
- Apparent power used to dimension equipment

$$S = VI \Rightarrow S = P \text{ if } \varphi = 0$$

1.3 Relation between \underline{S} , P and Q

- Active power P corresponds to real part of \underline{S}

$$P = \Re\{\underline{S}\} = VI \cos(\varphi)$$

- Reactive power Q corresponds to imaginary part of \underline{S}

$$Q = \Im\{\underline{S}\} = VI \sin(\varphi)$$

- Hence

$$\underline{S} = P + jQ$$

and

$$S = |\underline{S}| = \sqrt{P^2 + Q^2}$$

$p(t), P$	Watt	W	kW, MW
Q	Var	(VAr, Var, var)	kvar, Mvar
S	Volt-Ampere	VA	kVA, MVA

1.3 Power triangle in the complex plane

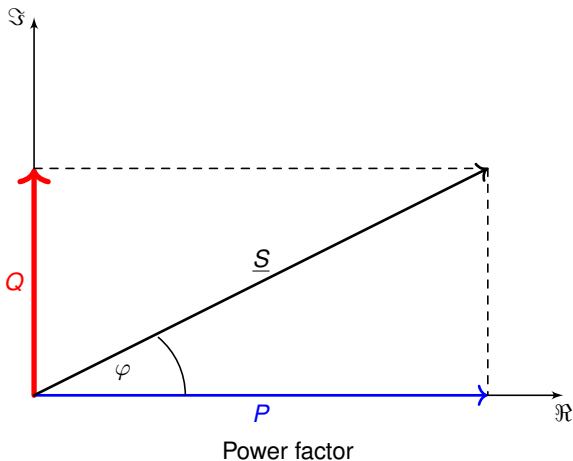

$$\cos(\varphi) = \frac{P}{|S|} = \frac{P}{\sqrt{P^2 + Q^2}}$$

- Under balanced conditions, the complex three-phase AC power is defined as

$$\begin{aligned}\underline{S}_{3\phi} &= \underline{V}_a \underline{I}_a^* + \underline{V}_b \underline{I}_b^* + \underline{V}_c \underline{I}_c^* \\ &= \underline{V}_a \underline{I}_a^* + \underline{V}_a e^{-j\frac{2\pi}{3}} \underline{I}_a^* e^{j\frac{2\pi}{3}} + \underline{V}_a e^{-j\frac{4\pi}{3}} \underline{I}_a^* e^{j\frac{4\pi}{3}} \\ &= 3 \underline{V}_a \underline{I}_a^* \\ &= 3 V I e^{j\varphi} \\ &= 3 V I \cos(\varphi) + j 3 V I \sin(\varphi) \\ &= 3 P_a + j 3 Q_a \text{ [VA]}\end{aligned}$$

- Three-phase active power: $P_{3\phi} = \Re\{\underline{S}_{3\phi}\} = 3 V I \cos(\varphi) = 3 P_a$ [W]
- Three-phase reactive power: $Q_{3\phi} = \Im\{\underline{S}_{3\phi}\} = 3 V I \sin(\varphi) = 3 Q_a$ [Var]

Under stationary and balanced conditions, total three-phase active power transmitted over a three-phase element is constant!

- Complex three-phase power

$$\underline{S}_{3\phi} = 3\underline{V}_{LN}I_L^* = 3VIe^{j\varphi} = 3VI \cos(\varphi) + j3VI \sin(\varphi)$$

- With $\sqrt{3}\underline{V}_{LN} = \underline{V}_{LL}$ and $|\sqrt{3}\underline{V}_{LN}| = |\underline{V}_{LL}| = \sqrt{3}V = U$

$$\underline{S}_{3\phi} = \sqrt{3}\underline{V}_{LL}I_L^* = \sqrt{3}UI \cos(\varphi) + j\sqrt{3}UI \sin(\varphi)$$

- These formulae are “hybrid” in so far as:
 - V_{LL} is the effective value of the *line voltage*
 - φ is the phase angle between the line current and the *phase-to-neutral voltage*.
- Three-phase active power: $P_{3\phi} = \Re\{\underline{S}_{3\phi}\} = \sqrt{3}UI \cos(\varphi)$
- Three-phase reactive power: $Q_{3\phi} = \Im\{\underline{S}_{3\phi}\} = \sqrt{3}UI \sin(\varphi)$

- Usual representation of physical quantities as product of numerical value and physical unit, e.g.

$$V = 400 \text{ kV}$$

- Alternative: representation of the quantity *relative* to another (base) quantity

$\text{value of quantity in pu} = \frac{\text{value of quantity in physical unit}}{\text{value of corresponding "base" in same unit}}$
--

- Division by "base" eliminates physical unit

→ per-unit (pu) system

- Example: base value for voltage $V_{\text{base}} = 400 \text{ kV}$

$$\frac{V}{V_{\text{base}}} = \frac{400 \text{ kV}}{400 \text{ kV}} = 1 \text{ pu}$$

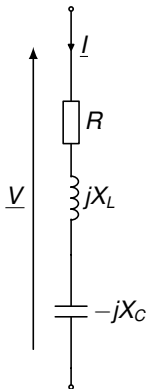

- 1 Choose two base quantities, e.g. S_B and V_B
 S_B can be either single- or three-phase power

$$S_{B3\phi} = 3S_{B1\phi}$$

- 2 Other values obtained via electrical laws

$$\text{Base current } I_B = \frac{S_{B1\phi}}{V_B} = \frac{S_{B3\phi}}{3V_B} = \frac{S_{B3\phi}}{\sqrt{3}U_B} \quad U_B = \sqrt{3}V_B$$

$$\text{Base impedance } Z_B = \frac{V_B}{I_B} = \frac{V_B^2}{S_{B1\phi}} = \frac{3V_B^2}{S_{B3\phi}} = \frac{U_B^2}{S_{B3\phi}}$$

$$\text{Base admittance } Y_B = G_B = B_B = \frac{1}{Z_B}$$

- V_B and I_B are always RMS values per phase!
- In non-stationary conditions usually frequency and/or time are also normalised

- In practice, it is often necessary to convert values from one per unit system to another one
- Example: machine parameters are given in per unit values with respect to machine rating and we want to convert them into per unit values with respect to base values of power system to which machine is connected
- This can be done as follows

Per unit value wrt first base: $x_1 = \frac{X}{X_{B,1}}$

Per unit value wrt second base: $x_2 = \frac{X}{X_{B,2}}$

Hence: $X = x_1 X_{B,1} = x_2 X_{B,2}$

→ Conversion from base 1 to base 2:

$$x_2 = x_1 \frac{X_{B,1}}{X_{B,2}}$$

1 Basics

2 **Transmission lines**

- Concentrated parameters
- Some brief remarks on cables
- Equivalent circuits for power lines

3 Power transformers

4 Rotating machines

5 Electric loads

6 Power-flow problem

Magnetic and electric fields of conducting power line

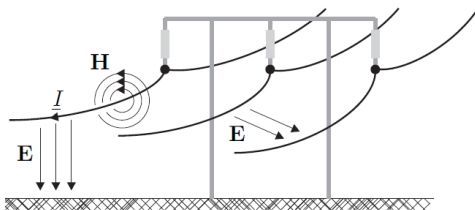

E... electric field

H... magnetic field

©G. Anderson

- Each power line has characteristic line parameters
- Parameters dependent on line geometry and material
- Parameters often indicated in [unit]/km and by giving the line length ℓ

Magnetic and electric fields
of conducting power line

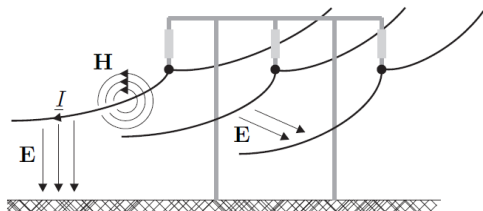

Power line model with
concentrated parameters

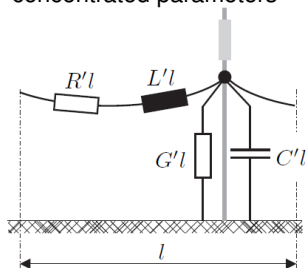

©G. Anderson

- Line resistance R' [Ω/km] \leftrightarrow Ohmic resistance of conductor
- Line inductance L' [H/km] \leftrightarrow Magnetic field of conductor
- Capacitance C' [F/km] \leftrightarrow Electric field of conductor
- Shunt conductance G' [S/km] \leftrightarrow Leakage currents at insulators

Magnetic and electric fields
of conducting power line

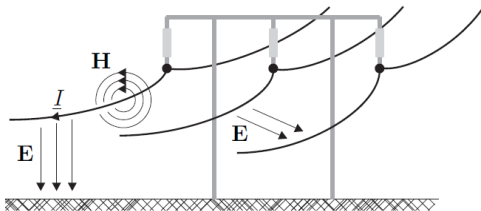

©G. Anderson

Power line model with
concentrated parameters

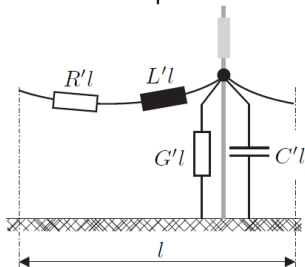

- For performing circuit analysis involving power lines (e.g. to determine the network conditions or design) we need to know the concentrated parameters of the lines
- Usually, concentrated parameters indicated by manufacturer

Please see the course book for a detailed derivation.

2.1 Resistance - Calculation

- For steel-reinforced aluminium conductors (ACSR), AC resistance is approximately same as DC resistance
- Reason: Skin-effect → reduced AC current in steel strands → increase in AC resistance by skin-effect comparable to higher DC current in steel strands
- Conductor losses result in heat dissipation → maximum conductor current limited, as long-term high temperatures ($> 80^{\circ}$) decrease mechanical strength of conductor material → line sags
- Line resistance operating at temperature of ϑ° can be calculated via

$$R' = R'_{20}(1 + \alpha(\vartheta - 20^{\circ}\text{C})) \text{ [R/m]}$$

$$R'_{20} = \frac{\rho_{20}}{A} \text{ resistance of conductor at } 20^{\circ}\text{C}$$

ρ_{20} ... specific resistance of of conductor material at 20°C

A ... effective conductor area

- For practical conductors, resistance values obtained via measurements

- Also, losses due to insulator leakage currents and corona
- Corona: high value of electric field strength at conductor surface causes air to become electrically ionised and to conduct
- Corona losses dependent on meteorological conditions (rain; humidity) and conductor surface irregularities
- For overhead lines, conductance G' can only be estimated from measurements, while it can be determined experimentally for cables
- Usually, conductance is very small and therefore most often neglected in power system studies

- Cables mostly used at low voltage levels (<110 kV)
- Often installed underground
- Physical characteristics of cables fundamentally different from overhead transmission lines (OHLs)!
- Main reasons:
 - Distance between conductors as well as between conductors and earth much smaller in cables than in OHLs
 - Conductors in cables typically surrounded by other metallic materials, e.g. skin
 - Insulation material of OHLs is air, while in cables materials such as paper, oil or SF₆ are used
- Consequences:
 - Inductance of OHLs usually higher as that of cables
 - Capacitance of cables usually much higher as that of OHLs

- Typical values for parameters of OHLs at 50 Hz

Rated voltage in kV	230	345	500	765
R' [Ω/km]	0.050	0.037	0.028	0.012
$X'_L = \omega L'$ [Ω/km]	0.407	0.306	0.271	0.274
$Y'_C = \omega C'$ [$\mu\text{S}/\text{km}$]	2.764	3.765	4.333	4.148

- Typical values for parameters of cables at 50 Hz

Rated voltage in kV	115	230	500
R' [Ω/km]	0.059	0.028	0.013
$X'_L = \omega L'$ [Ω/km]	0.252	0.282	0.205
$Y'_C = \omega C'$ [$\mu\text{S}/\text{km}$]	192.0	204.7	80.4

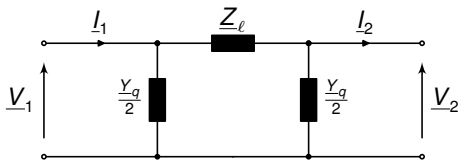

where:

$$\underline{Z}_\ell = \underline{Z}_W \sinh(\underline{\gamma}\ell)$$

$$\frac{Y_q}{2} = \frac{\cosh(\underline{\gamma}\ell) - 1}{\underline{Z}_W \sinh(\underline{\gamma}\ell)} = \frac{1}{\underline{Z}_W} \tanh\left(\frac{\underline{\gamma}\ell}{2}\right)$$

$$\underline{\gamma} = \sqrt{(R' + j\omega L')(G' + j\omega C')}$$

$$\underline{Z}_W = \sqrt{\frac{R' + j\omega L'}{G' + j\omega C'}}$$

These parameters correspond to exact relations between currents and voltages according to wave equation for $x = 0$ and $x = \ell$

2.3 π -equivalent circuit of homogeneous power line - The case $|\underline{\gamma}\ell| \ll 1$

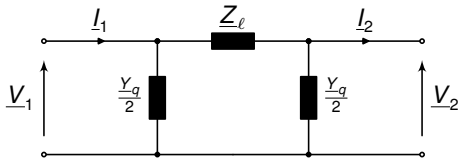

- For $|\underline{\gamma}\ell| \ll 1$, the expressions for \underline{Z}_ℓ and \underline{Y}_q can be simplified

$$\underline{Z}_\ell = \underline{Z}_W \sinh(\underline{\gamma}\ell) \approx \underline{Z}_W \underline{\gamma}\ell = \underline{Z}'\ell$$

$$\frac{\underline{Y}_q}{2} = \frac{1}{\underline{Z}_W} \tanh\left(\frac{(\underline{\gamma}\ell)}{2}\right) \approx \frac{1}{\underline{Z}_W} \frac{\underline{\gamma}\ell}{2} = \frac{\underline{Y}'\ell}{2}$$

→ Concentrated elements \underline{Z}_ℓ and \underline{Y}_q can be computed from distributed parameters R' , L' , G' and C' if $|\underline{\gamma}\ell| \ll 1$

$$\boxed{\begin{aligned}\underline{Z}_\ell &= \underline{Z}'\ell = (R' + jX')\ell \\ \frac{\underline{Y}_q}{2} &= \frac{\underline{Y}'\ell}{2} = \frac{(G' + jB')\ell}{2}\end{aligned}}$$

- 1 Basics
- 2 Transmission lines
- 3 Power transformers**
 - Transformation ratio and equivalent single-phase circuit of three-phase transformers
- 4 Rotating machines
- 5 Electric loads
- 6 Power-flow problem

3 Three-phase transformer - Configuration of primary and secondary side

Four main different configuration possibilities: Y-Y, Y-Delta, Delta-Y, Delta-Delta

1. Y-Y-configuration

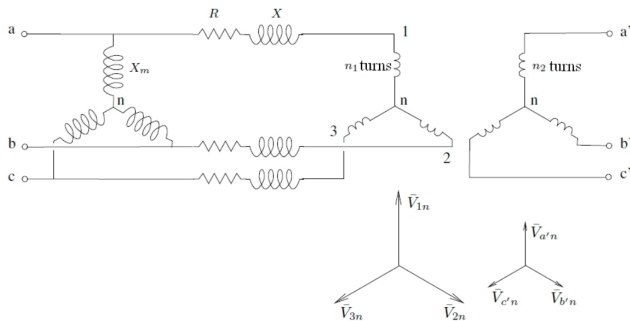

- Preferred at very high voltage level since voltage across each coil is $\sqrt{3}$ lower
- Possibility to connect neutral to ground (safety protection)

2. Delta-Delta-configuration

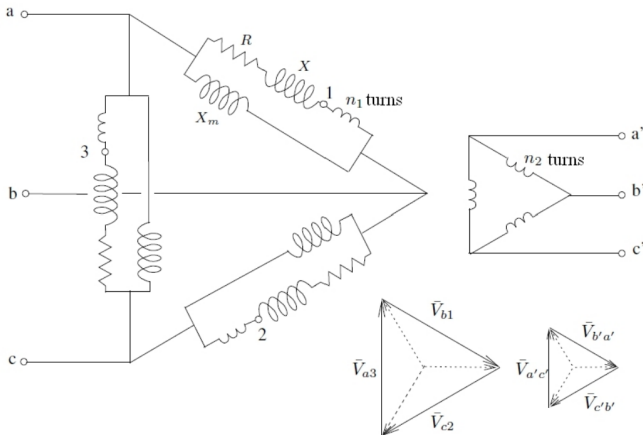

- Preferred for high currents, as currents in phases $\sqrt{3}$ lower
- Also used to eliminate harmonics

3. Y-Delta-configuration

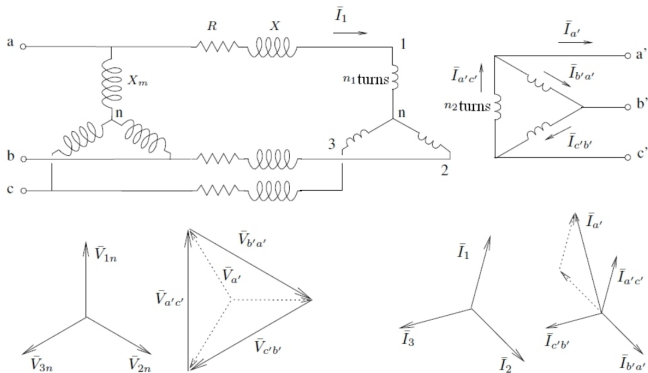

- Frequent transformer configuration connecting generator to grid
- On high-voltage side, neutral point is grounded (for protection)

- Standardized abbreviation of I.E.C. (International Electrotechnical Commission)
- Classification of transformer configuration consists of 2 letters and 1 integer
- First letter: Configuration of high-voltage side; upper-case letter used (**Y** or **D**)
- Second letter: Configuration of low-voltage side; lower-case letter used (**y** or **d**)
- Integer: Phase shift between voltages at primary and secondary winding of the same phase as multiple of 30° ($\pi/6$) assuming the transformer is ideal
- Additionally in Y-connection: **n** after **Y** or **y** to indicate that neutral is grounded

- In balanced operation, in principle can use single-phase equivalent circuit for analysis
- But if analysing Yd or Dy connections, need to consider
 - ① Not same voltages on primary and secondary side: one has phase voltages the other line voltages
 - Transformation ratio also affected!
 - ② Phase and line voltages also differ in phase
 - Additional phase displacement Phase displacement is integer multiple of $\pi/6 = 30^\circ$

- Impact on amplitude considered by introducing additional scalar k
 - Dy-configuration: $k = \frac{1}{\sqrt{3}}$
 - Yd-configuration: $k = \sqrt{3}$
 - Yy or Dd: $k = 1$
- Impact on phase displacement considered by introducing additional phase shift element

$$e^{j\frac{p\pi}{6}},$$

where $p = \{0, 1, \dots, 11\}$ is an integer

→ Complex transformation ratio

$$\underline{c} = k \frac{N_1}{N_2} e^{j\frac{p\pi}{6}}$$

- Note: $|e^{j\frac{p\pi}{6}}| \rightarrow$ amplitude of transformation not influenced by p

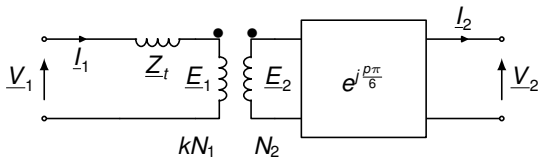

- Combine single-phase transformer model with complex transformation ratio
- Then

$$\underline{E}_1 = \underline{c} \underline{V}_2$$

$$\underline{I}_2 = \underline{c}^* \underline{I}_1$$

- 1 Basics
- 2 Transmission lines
- 3 Power transformers
- 4 Rotating machines**
 - Synchronous machine
 - Induction machine
- 5 Electric loads
- 6 Power-flow problem

4.1 Three-phase machine induced voltage

We place one stator winding as shown below at the point of peak flux density ($\alpha = 0$):

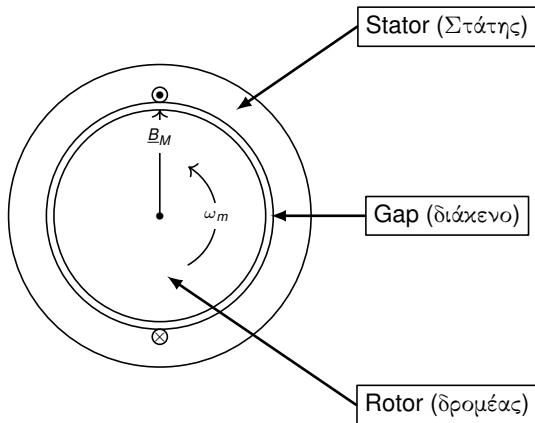

The magnetic field generated by the rotor B_M is seen by the stator winding as a varying field given by $B = B_M \cos(\omega t)$.

4.1 Three-phase machine induced voltage

Following the same analysis for three windings spaced 120° apart:

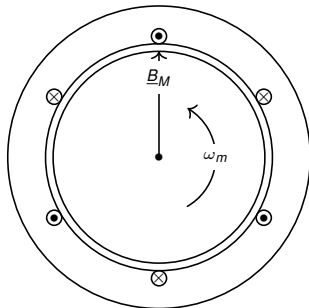

Gives (in Volt):

$$e_{aa'} = N_c \Phi_M \omega \sin(\omega t)$$

$$e_{bb'} = N_c \Phi_M \omega \sin(\omega t - 120^\circ)$$

$$e_{cc'} = N_c \Phi_M \omega \sin(\omega t - 240^\circ)$$

4.1 Three-phase machine induced voltage

The peak voltage at each phase is:

$$E_{max} = N_c \Phi_M \omega = N_c \Phi_M 2\pi f$$

with the RMS voltage:

$$E_{RMS} = \frac{N_c \Phi_M 2\pi f}{\sqrt{2}} = \sqrt{2} N_c \Phi_M \pi f = 4.44 N_c \Phi_M f$$

- If the generator is connected in Y, then it's voltage is $\sqrt{3}E_{RMS}$.
- If the generator is connected in Delta, then it's voltage is E_{RMS} .

In phasor representation:

$$\underline{E}_A = E_{RMS} \angle 0^\circ$$

$$\underline{E}_B = E_{RMS} \angle -120^\circ$$

$$\underline{E}_C = E_{RMS} \angle -240^\circ$$

The (simplified) equivalent model is given:

$$\underline{V}_A = \underline{E}_A - jX_I I_A - jX_A I_A - R_A I_A = \underline{E}_A - jX_S I_A - R_A I_A$$

with $X_S = X + X_A$ the synchronous reactance of the generator.

4.1 (Simplified) equivalent circuit of synchronous generator

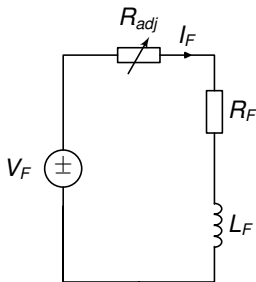
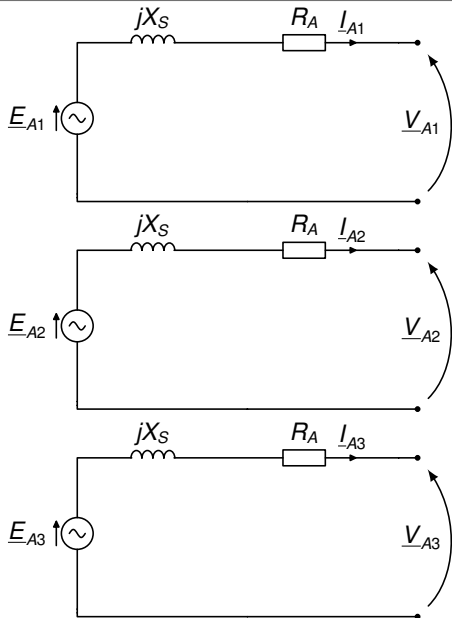

The output power is:

$$P_{out} = 3V_A I_A \cos(\theta) \quad Q_{out} = 3V_A I_A \sin(\theta)$$

where θ is the angle between \underline{V}_A and \underline{I}_A .

If we ignore the resistance R_A (since $R_A \ll X_S$), we can use the power flow equations over a reactance to get the generator power output and torque:

$$P = \frac{3V_A E_A}{X_S} \sin(\delta)$$

$$\tau = \frac{3V_A E_A}{\omega_m X_S} \sin(\delta)$$

$$Q = \frac{3V_A E_A}{X_S} \cos(\delta) - \frac{3V_A^2}{X_S}$$

with δ the angle between \underline{E}_A and \underline{V}_A , also called *torque angle*.

Q1: What is the maximum power of the generator, if we keep E_A and V_A constant?

Q2: Can you rewrite the equations with line voltages instead of phase voltages?

The synchronous generator operates as generator or motor:

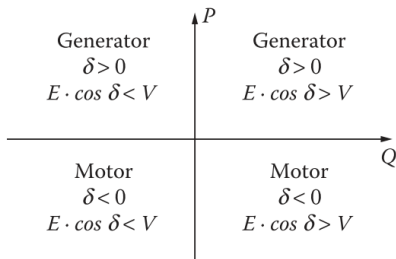

The following limits are imposed:

- Mechanical power limits $P_{m,max}$ and $P_{m,min}$
- Stator thermal limit I_{max}
- Maximum internal voltage limit E_{max}
- Stability limit δ_{max}

Capability curves

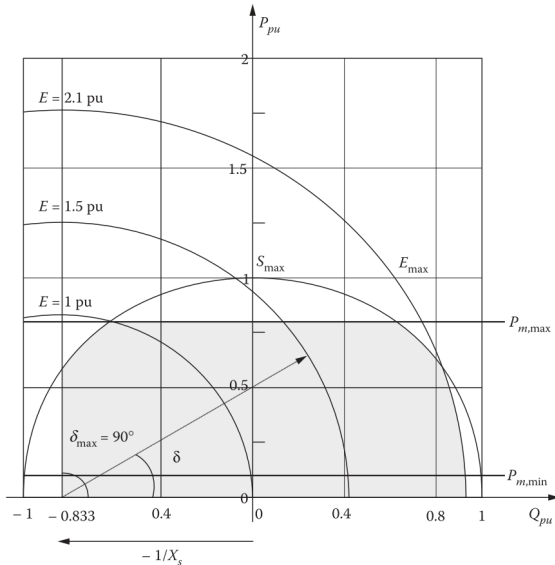

The equation governing the rotor motion is called the *swing equation*:

$$J \frac{d^2 \theta_m}{dt^2} = J \frac{d\omega_m}{dt} = T_a = T_m - T_e \quad [\text{N}\cdot\text{m}]$$

where:

- J is the total moment of inertia of the rotor mass in $\text{kg} - \text{m}^2$
- θ_m is the angular position of the rotor with respect to a stationary axis in (rad)
- $\omega_m = \frac{d\theta_m}{dt}$ is the angular speed of the rotor with respect to a stationary axis in (rad/s)
- t is time in seconds (s)
- T_m is the mechanical torque supplied by the prime mover in N-m
- T_e is the electrical torque output of the alternator in N-m
- T_a is the net accelerating torque, in N-m

Multiplying both sides by ω_m , the can rewrite the equations as:

$$M \frac{d^2 \theta_m}{dt^2} = M \frac{d\omega_m}{dt} = P_a = P_m - P_e \quad [\text{W}]$$

where P_a , P_m and P_e are the net, mechanical and electrical powers, respectively. $M = J\omega_m$ is the angular momentum of the rotor.

A useful representation is by introducing the inertia constant of the machine:

$$H = \frac{\text{stored kinetic energy in mega joules at synchronous speed}}{\text{machine rating in MVA}} = \frac{J\omega_s^2}{2S_{\text{rated}}} \text{ MJ/MVA}$$

where S_{rated} is the three-phase power rating of the machine in MVA.

$$M \frac{d\omega_m}{dt} + D(\omega_m - \omega_s) = P_m - P_e - P_{losses} \quad [\text{W}]$$

where P_{losses} are the electrical losses (stator) and D is the so-called damping constant of the machine representing mechanical rotational losses.

- The induction machine is an electrical machine in which the stator windings are fed through a three-phase voltage source, while the rotor windings are short circuited and are circulated by currents induced by the stator.
- In balanced steady-state conditions, the induction machine has an analog behavior to that of a transformer and hence a transformer model can be used to represent this machine.

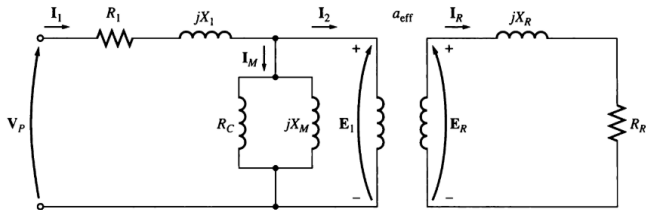

4.2 Induction machine: Per-phase equivalent model

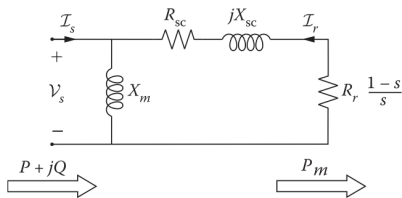

- P and Q : Active and reactive powers at the machine terminals.
- V_s and I_s : Voltage and current at the generator terminals (stator).
- $Z_{sc} = R_{sc} + jX_{sc}$: Short-circuit impedance comprising that of the stator plus that of the rotor referred to the stator.
- X_m : Per-phase reactance modeling the magnetization of the ferromagnetic core.
- s : Slip of the machine obtained as $s = (\omega_s - \omega)/\omega_s$, where ω_s is the synchronous speed in rad/s.
- P_m : Mechanical power exchanged by the machine with the outer world, which can be expressed as $P_m = I_r^2 R_r (1 - s)/s$

A. Gomez-Exposito, A. J. Conejo, and C. A. Cañizares, Electric Energy Systems Analysis and Operation, 2018.

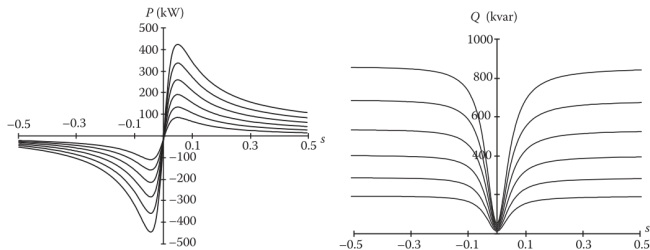

- Special cases: $s = 1 \rightarrow$ locked-rotor, $s = 0 \rightarrow$ no-load
- Operating limits:
 - Stator thermal limit I_{max}
 - Dielectric insulation or maximum feeding voltage limit $V_{s,max}$
 - Stability or magnetizing limit (from curve)

- 1 Basics
- 2 Transmission lines
- 3 Power transformers
- 4 Rotating machines
- 5 Electric loads**
- 6 Power-flow problem

One of the most well-known load models is the *exponential*:

$$P(V) = P_0 \left(\frac{V}{V_0} \right)^{k_{PV}}$$

$$Q(V) = Q_0 \left(\frac{V}{V_0} \right)^{k_{QV}}$$

- $P(V)$, $Q(V)$ are the active and reactive power consumed by the load at voltage V
- P_0 , Q_0 are the active and reactive powers consumed at a voltage V_0
- k_{PV} , k_{QV} are load-voltage parameters depending on the type of load
 - $k_{PV} = k_{QV} = 2$: constant impedance load (Z)
 - $k_{PV} = k_{QV} = 1$: constant current load (I)
 - $k_{PV} = k_{QV} = 0$: constant power load (P)

Considering frequency sensitivity:

$$P(V, f) = P(V) \left(1 + k_{Pf} \frac{f - f_0}{f_0} \right)$$

$$Q(V, f) = Q(V) \left(1 + k_{Qf} \frac{f - f_0}{f_0} \right)$$

- $P(V, f)$, $Q(V, f)$ are the active and reactive power consumed by the load at voltage V and frequency f
- $P(V)$, $Q(V)$ were given in previous slide
- f_0 is the nominal frequency (usually 50/60 Hz)
- k_{Pf} , k_{Qf} are load-frequency parameters depending on the type of load

Table 3.3 Typical load model parameters (IEEE, 1993)

Type of load	Power factor	k_{pV}	k_{qV}	k_{Pf}	k_{Qf}
Residential	0.87–0.99	0.9–1.7	2.4–3.1	0.7–1	–1.3 to –2.3
Commercial	0.85–0.9	0.5–0.8	2.4–2.5	1.2–1.7	–0.9 to –1.6
Industrial	0.8–0.9	0.1–1.8	0.6–2.2	–0.3–2.9	0.6–1.8

1 Basics

2 Transmission lines

3 Power transformers

4 Rotating machines

5 Electric loads

6 **Power-flow problem**

- Problem formulation
- Power flows on transmission lines
- Basic power flow problem
- Basic bus types
- Inequality constraints
- DC power flow equations

- A power flow computation is an efficient tool to obtain the *complete state* of the system, i.e., all complex voltages at all nodes, under balanced steady-state conditions
 - Once the voltages are known, the currents and powers can also be computed
 - Power flow computations are usually performed using dedicated software
 - Useful tool for both analysis of an existing network and of projected network expansions or load growth
- Power flow computations are the most used computations in power systems!

- In general, the power flow problem (also called load flow problem) is formulated as a set of nonlinear equations

$$\mathbf{f}(\mathbf{x}, \mathbf{u}, \mathbf{p}) = \mathbf{0},$$

where

- \mathbf{f} is an n -dimensional nonlinear function
- \mathbf{x} is an n -dimensional complex vector containing the states of the system. These are the unknown voltage magnitudes and phase angles at the nodes in the system.
- \mathbf{u} is an input vector with known entries (e.g., voltages at generator nodes with voltage control)
- \mathbf{p} is a vector that contains the parameters of the network components (e.g., line and transformer impedances)

- The power flow problem consists in formulating the equations in \mathbf{f} and then solving them with respect to \mathbf{x}
- Both aspects are covered in the remainder of this part of the lecture
- A necessary condition for the power flow problem to have a physically meaningful solution is that \mathbf{f} and \mathbf{x} have the same dimension, since then we have the same number of unknowns as equations
- But even then, there might not be a unique solution or even no solution at all!

- Expression for \underline{I}_k , $k = 1, \dots, N$ can be written in matrix form

$$\underline{\mathbf{I}} = \underline{\mathbf{Y}}\underline{\mathbf{V}},$$

where

- $\underline{\mathbf{I}}$ is vector with current injections \underline{I}_k , $k = 1, \dots, N$
- $\underline{\mathbf{V}}$ is vector with nodal voltages $\underline{V}_k = V_k e^{j\theta_k}$, $k = 1, \dots, N$
- $\underline{\mathbf{Y}} = \underline{\mathbf{G}} + j\underline{\mathbf{B}}$ is *nodal admittance matrix* with elements

$$\underline{y}_{kk} = \mathcal{G}_{kk} + j\mathcal{B}_{kk} = \underline{y}_k^{sh} + \sum_{m \in \mathcal{N}_k} (\mathcal{B}_{km}^{sh} + \underline{y}_{km})$$

$$\underline{y}_{km} = \mathcal{G}_{km} + j\mathcal{B}_{km} = -\underline{y}_{km} a_{km}^{-1} e^{-j\varphi_{km}} = -(\mathcal{G}_{km} + j\mathcal{B}_{km}) a_{km}^{-1} e^{-j\varphi_{km}}$$

- Admittance matrix is compact representation of network interconnections
- Synchronous generators are modeled with their Norton equivalent

Main steps:

- 1 We derive the per-phase per-unit equivalent circuit
- 2 We add the per-unit series impedance of transformer and transmission lines.
- 3 We transform each voltage source in series with an impedance to an equivalent current source in parallel with that impedance using Norton's theorem.
- 4 We expressed impedance values as admittance.
- 5 We use Kirchhoff's current law to formulate the system equations.

Note: Current sources always flow into a node, hence power flow for generators will be positive, power flow for motors and loads will be negative.

- Now, k -th component of nodal current vector \underline{I} can be written as

$$\begin{aligned} I_k &= \underline{y}_{kk} V_k + \sum_{m \in \mathcal{N}_k} \underline{y}_{km} V_m \\ &= (\mathcal{G}_{kk} + j\mathcal{B}_{kk}) V_k e^{j\theta_k} + \sum_{m \in \mathcal{N}_k} (\mathcal{G}_{km} + j\mathcal{B}_{km}) V_m e^{j\theta_m} \end{aligned}$$

- Note: In presence of transformers, admittance matrix is NOT necessarily symmetric
- Note: In presence of transformers, the series admittance \underline{Y}_{km} between nodes k and m and the (k, m) -th entry \underline{y}_{km} of admittance matrix do NOT have the same values!

- For practical large power systems, admittance matrix is usually sparse
- Sparsity typically increases with network size
- This sparsity can be used effectively to design efficient numerical algorithms to perform power flow computations and other calculations in power systems
- Example: a power system with 1000 buses and 1500 branches (=lines and transformers) usually has a degree of sparsity greater than 99%, i.e., less than 1% of entries of admittance matrix have nonzero values

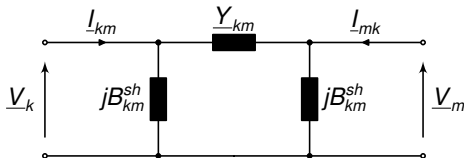

- Assume shunt conductance of line is small $\rightarrow Y_{km}^{sh} = jB_{km}^{sh}$
- Complex current from node k to m

$$\underline{I}_{km} = \underline{Y}_{km}(\underline{V}_k - \underline{V}_m) + jB_{km}^{sh}\underline{V}_k$$

- Complex power from node k to m

$$\begin{aligned} \underline{S}_{km} &= \underline{V}_k \underline{I}_{km}^* \\ &= \underline{V}_k \left(\underline{Y}_{km}^* (\underline{V}_k^* - \underline{V}_m^*) - jB_{km}^{sh} \underline{V}_k^* \right) \\ &= \underline{Y}_{km}^* \underline{V}_k e^{j\theta_k} (\underline{V}_k e^{-j\theta_k} - \underline{V}_m e^{-j\theta_m}) - jB_{km}^{sh} \underline{V}_k^2 \end{aligned}$$

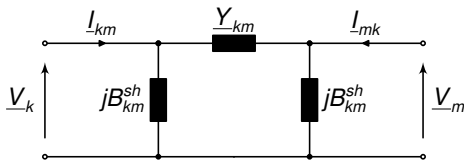

- Define short-hand $\theta_{km} = \theta_k - \theta_m$
- Split $\underline{S}_{km} = P_{km} + jQ_{km}$ into real and imaginary part
- Active power flow

$$P_{km} = \Re(\underline{S}_{km}) = V_k^2 G_{km} - V_k V_m (G_{km} \cos(\theta_{km}) + B_{km} \sin(\theta_{km}))$$

- Reactive power flow

$$Q_{km} = \Im(\underline{S}_{km}) = -V_k^2 (B_{km} + B_{km}^{sh}) + V_k V_m (B_{km} \cos(\theta_{km}) - G_{km} \sin(\theta_{km}))$$

6.2 Active and reactive power flows on transmission line from node m to node k

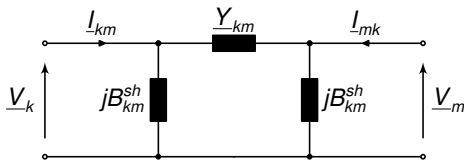

- Power flows from m to k can be obtained in same way
- Note that

$$\sin(\theta_{mk}) = \sin(-\theta_{km}) = -\sin(\theta_{km}) \quad \cos(\theta_{mk}) = \cos(-\theta_{km}) = \cos(\theta_{km})$$

- Active power flow

$$P_{mk} = V_m^2 G_{km} - V_k V_m G_{km} \cos(\theta_{km}) + V_k V_m B_{km} \sin(\theta_{km})$$

- Reactive power flow

$$Q_{mk} = -V_m^2 (B_{km} + B_{km}^{sh}) + V_k V_m B_{km} \cos(\theta_{km}) + V_k V_m G_{km} \sin(\theta_{km})$$

- Using admittance matrix, complex power injection at node k is

$$\begin{aligned} \underline{S}_k &= \underline{V}_k \underline{I}_k^* = V_k e^{j\theta_k} \left((\mathcal{G}_{kk} + j\mathcal{B}_{kk}) V_k e^{j\theta_k} + \sum_{m \in \mathcal{N}_k} (\mathcal{G}_{km} + j\mathcal{B}_{km}) V_m e^{j\theta_m} \right)^* \\ &= V_k e^{j\theta_k} \left((\mathcal{G}_{kk} - j\mathcal{B}_{kk}) V_k e^{-j\theta_k} + \sum_{m \in \mathcal{N}_k} (\mathcal{G}_{km} - j\mathcal{B}_{km}) V_m e^{-j\theta_m} \right) \end{aligned}$$

- Identifying real and imaginary part of above expression, yields active and reactive power flows

$$P_k = \mathcal{G}_{kk} V_k^2 + \underbrace{V_k \sum_{m \in \mathcal{N}_k} V_m (\mathcal{G}_{km} \cos(\theta_{km}) + \mathcal{B}_{km} \sin(\theta_{km}))}_{=f_k(\theta_1, \dots, \theta_N, V_1, \dots, V_N)}$$

$$Q_k = -\mathcal{B}_{kk} V_k^2 + \underbrace{V_k \sum_{m \in \mathcal{N}_k} V_m (\mathcal{G}_{km} \sin(\theta_{km}) - \mathcal{B}_{km} \cos(\theta_{km}))}_{=g_k(\theta_1, \dots, \theta_N, V_1, \dots, V_N)}$$

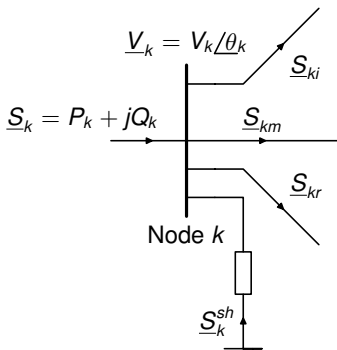

- Consider a network with $N \geq 2$ nodes
- To each node k , $k = 1, \dots, N$, there are 4 main variables associated
 - V_k voltage magnitude
 - θ_k voltage phase angle
 - P_k net active power (algebraic sum of generation and load)
 - Q_k net reactive power (algebraic sum of generation and load)
- We may also associate additional *operational constraints* to a node k (e.g., generation or voltage limits)

- Main variables of power flow problem: V_k , θ_k , P_k and Q_k
- Usually some of these variables are known (i.e., fixed) and some are unknown (i.e., need to be calculated via power flow computation)
- Depending on which variables are known and which are unknown, we can distinguish two main bus types
 - 1) **PQ bus**: P_k and Q_k are known; V_k and θ_k are calculated
 - 2) **PV bus**: P_k and V_k are known; Q_k and θ_k are calculated

- **PQ bus** usually used to represent load buses without voltage control

Justification: active and reactive power demand of load bus is often known (at least with certain accuracy)

- **PV bus** bus typically used to represent generator buses with voltage control

Justification: Synchronous machine usually equipped with automatic voltage regulator (AVR) that adjusts excitation voltage such that terminal voltage magnitude (or other voltage magnitude close to generator) is kept at set value

- **PV bus** also used to represent synchronous compensators

Justification: Synchronous compensators (also: synchronous condensers) are synchronous machines that do not generate any active power (besides internal losses) and that are used for reactive power and voltage control

- In practical power systems, majority of buses are PQ buses (typically over 80%)

- In addition to PQ and PV buses a third bus type is needed: the **V θ bus**
- 1) Active power losses are unknown in advance \rightarrow can not specify all active power injections P_k at all buses *before* solving power flow equations

$$\sum_{k=1}^N P_k = \text{active power losses} = f_k(\theta_1, \dots, \theta_N, V_1, \dots, V_N) = ???$$

- 2) Voltage phase angles θ_k, θ_m only appear through differences $\theta_{km} = \theta_k - \theta_m$ in power flow equations
 - We can add arbitrary constant c to all phase angles in network without changing electric state and power flows in network
- \rightarrow Need to take phase angle at one bus as *reference phase angle*
- At slack bus i active power balance equation replaced by

$$\theta_i = 0 \quad 0: \text{arbitrary value; any other constant would work as well}$$

- At slack bus i , active power injection takes value

$$P_i = - \sum_{k=1, k \neq i}^N P_k + p,$$

where all P_k in the sum are known and p is a variable that is determined at the end of power flow computation to satisfy above active power balance

- Need to select a bus at which a generator is connected as slack bus (= *slack generator*)

- What about reactive power losses at slack bus?
 - Not possible to specify reactive power injections at all buses
 - Q_k not specified at PV buses (= for reactive power each PV bus acts as slack bus)

→ No problem, as long as there is at least one PV bus
- What data is needed at slack bus?
 - Need to specify either V_i or Q_i
 - As generator is connected at slack bus, it is natural to specify voltage magnitude V_i

→ Slack bus = $V\theta$ bus

6.4 Basic bus types - Summary

Bus configuration

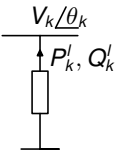
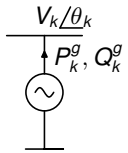
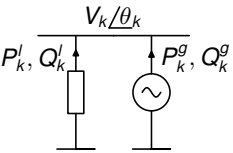
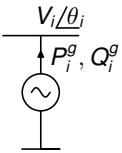
Load bus	Generator bus	Load & generator bus	Slack bus i
V_k/θ_k 	V_k/θ_k 	V_k/θ_k 	V_i/θ_i 

Bus type

PQ bus	PQ bus	PV bus	PQ bus	PV bus	V θ bus
--------	--------	--------	--------	--------	----------------

Power balance equations

$P_k^l = f_k(\dots)$	$P_k^g = f_k(\dots)$	$P_k^g + P_k^l = f_k(\dots)$	$\theta_i = 0$
$Q_k^l = g_k(\dots)$	$Q_k^g = g_k(\dots)$	$Q_k^g + Q_k^l = g_k(\dots)$	$V_i = V_i^r$
	$V_k = V_k^r$	$V_k = V_k^r$	

Unknowns

V_k, θ_k	V_k, θ_k	θ_k	V_k, θ_k	θ_k	-
-----------------	-----------------	------------	-----------------	------------	---

Note: With chosen convention in this module $P_k^l \leq 0$, $P_k^g \geq 0$; $Q_k < 0 \rightarrow$ ind. react. pow.

- Formulation of power flow problem typically involves a set of inequality constraints to impose operating limits on certain variables
- Examples: voltage magnitude (PQ buses) and reactive power (PV buses)
- Mathematically these constraints can be formulated as

$$Q_k^{\min} \leq Q_k \leq Q_k^{\max}$$

$$V_k^{\min} \leq V_k \leq V_k^{\max}$$

- If bus limit is violated, then bus status has to be changed to enforce equality constraint at limiting value
- This is usually done by changing the bus type
- Example: reactive power constraint violated at a PV bus \rightarrow convert that bus into PQ bus (then Q is specified and V becomes a variable)
- Other constraints: line power flows, active power generation, phase shifter angles, ...

- Thus far, we have used exact expressions of power flow equations
- Yet, as power flow equations are solved very frequently in power system operation and planning it is preferable to also have a set of equations that can be solved very fast
- Such equations can be obtained by approximating the exact power flow equations
- The DC power flow equations are the most common approximation of this type

DC power flow equations are simplified equations obtained after

- 1 Neglecting reactive power flows in all branches
- 2 Neglecting active power losses in all branches
- 3 Assuming all voltage magnitudes equal to 1 pu
- 4 Angle difference between buses is small

- Hence, we assume
 - $V_k = 1$ pu, $k = 1, \dots, N$
 - $G_{km} = 0$ for all $k = 1, \dots, N$, $m = 1, \dots, N$
 - $B_{km} = -\frac{1}{X_{km}}$ for all $k = 1, \dots, N$, $m = 1, \dots, N$
 - $a_{km} = 1$ (transformer ratio influences mainly reactive power flows)
- Linearisation of active power flow from node k to node m

$$\begin{aligned} P_{km}^{\text{DC}} &= \frac{\partial P_{km}}{\partial \theta_k} \theta_k + \frac{\partial P_{km}}{\partial \theta_m} \theta_m \\ &= \frac{\cos(\theta_{km})}{X_{km}} \theta_k + \frac{-\cos(\theta_{km})}{X_{km}} \theta_m \\ &= \frac{\cos(\theta_{km})}{X_{km}} \theta_{km} \\ &\approx \frac{1}{X_{km}} \theta_{km} \quad (\text{approximation valid for small phase angle differences}) \end{aligned}$$

- DC power flow equation from node k to node m

$$P_{km}^{\text{DC}} = \frac{\theta_{km}}{X_{km}}$$

- DC power flow equation analogous to Ohm's law applied to a resistor
 - P_{km}^{DC} is DC current
 - θ_k and θ_m are DC voltages at resistor terminals
 - X_{km} is resistance

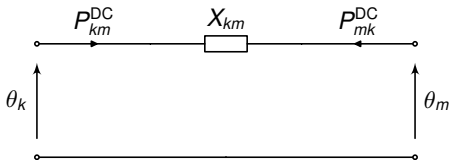

- DC power flow at node k

$$P_k^{\text{DC}} = \sum_{m \in \mathcal{N}_k} \frac{\theta_{km}}{X_{km}}$$

- Active power losses neglected

$$\sum_{k=1}^N P_k^{\text{DC}} = 0 \quad \Leftrightarrow \quad P_1 = - \sum_{k=2}^N P_k^{\text{DC}}$$

- No slack bus needed to compensate for unknown active power losses (but still need angle reference bus)
- DC power flow equations can be extended to include phase shifters (not done here)

- DC power flow can be written in matrix form as follows

$$\mathbf{P}^{\text{DC}} = \mathbf{A}'\theta,$$

where

- \mathbf{P} is vector of net active power injections
- θ is vector of voltage angles
- \mathbf{A}' is nodal admittance matrix with elements

$$\begin{aligned}A_{km} &= -X_{km}^{-1} \\ A_{kk} &= \sum_{m \in \mathcal{N}_k} X_{km}^{-1}\end{aligned}$$

- Matrix \mathbf{A}' is singular \rightarrow no unique solution for θ
- To make system of equations solvable, need to (arbitrarily) chose one bus as angle reference and remove row and column associated with that bus from \mathbf{A}' ; we shall call that reduced matrix \mathbf{A}

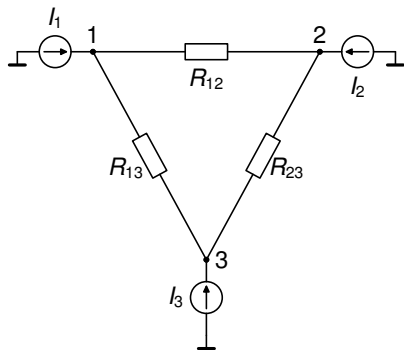
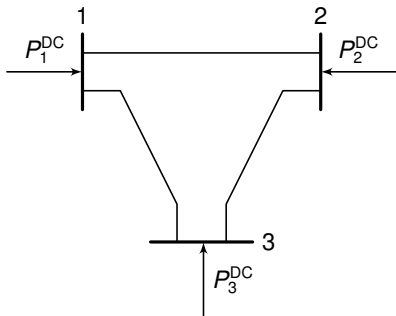

- Linearised model $\mathbf{P}^{\text{DC}} = \mathbf{A}'\theta$ can be interpreted as network of resistors fed by DC current sources
- Then \mathbf{P}^{DC} are the nodal DC current injections, θ the nodal DC voltages and \mathbf{A}' is the nodal conductance matrix
- Angle reference bus = DC voltage reference bus = Bus 1