



Cyprus
University of
Technology

EEN452 - Control and Operation of Electric Power Systems

Part 4: Voltage control

<https://sps.cut.ac.cy/courses/een452/>

Dr Petros Aristidou

Department of Electrical Engineering, Computer Engineering & Informatics

Last updated: February 16, 2022

After this part of the lecture and additional reading, you should be able to ...

- 1 ... understand the fundamentals of voltage and var control;
- 2 ... describe and analyse different voltage control mechanisms; and,
- 3 ... perform calculations and sizing concerning voltage control.

- 1 Fundamentals**
- 2 Static compensation
- 3 Synchronous machine
- 4 Synchronous condenser
- 5 FACTS devices
- 6 Load Tap Changers
- 7 Impact of renewables in LV systems

Two major differences between frequency and voltage controls:

- frequency = "signal" available throughout whole system, whatever its size. Nothing similar for voltage. Example:
 - change of active power setpoint of a generator \Rightarrow frequency variation sensed by all speed governors \Rightarrow reaction of all power plants under frequency control
 - change of voltage setpoint of a generator \Rightarrow voltages at buses in some neighbourhood are modified \Rightarrow among the other generators under voltage control, only those in some neighbourhood have their reactive power modified
- frequency hold very close to its nominal value
- voltage control is comparatively less accurate
- deviation of $\pm 5\%$ with respect to nominal value is very acceptable
- in any case, voltage drops along the network impedances is inevitable.

However, voltages must be kept within acceptable limits:

- not too high:
 - degradation of insulating materials
 - damage to sensitive (electronic) equipment
 - etc.
- not too low:
 - higher Joule losses in network
 - disturbed operation of some components:
 - commutation failures of power electronics
 - tripping of some loads (e.g. motors) by undervoltage protections
 - stalling of induction motors

Two main ways of acting on voltages:

- ① inject (resp. extract) reactive power into (resp. from) the network
- ② adjust the ratios of transformers equipped with load tap changers

- 1 Fundamentals
- 2 Static compensation**
- 3 Synchronous machine
- 4 Synchronous condenser
- 5 FACTS devices
- 6 Load Tap Changers
- 7 Impact of renewables in LV systems

Thevenin's theorem: Seen from one port, a linear circuit can be replaced by an equivalent composed of:

- a voltage source (E_{th}) = voltage that appears at the port when it is opened
- in series with an impedance ($Z_{th} = R_{th} + jX_{th}$) = impedance seen from the port after having removed all sources. Or, $Z_{th} = jX_{th}$ if we assume $R_{th} \ll X_{th}$

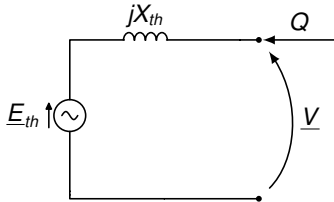

$$Q = \frac{V^2 - VE_{th}}{X_{th}}$$

2 Thevenin equivalent circuit model of a power system

Linear approximation around E_{th} :

$$\left. \frac{dQ}{dV} \right|_{V=E_{th}} = \left. \frac{X_{th}}{2V - E_{th}} \right|_{V=E_{th}} = \frac{X_{th}}{E_{th}}$$

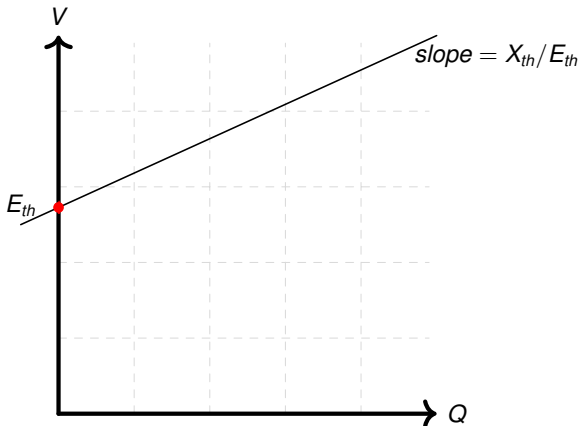

2 Voltage correction by shunt capacitors or inductors

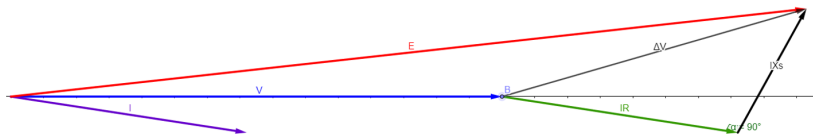
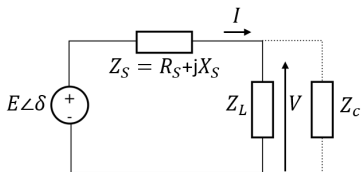

$$\Delta V = E - V = Z_S I_S, \quad I = \frac{P - jQ}{V}$$

$$\Delta V = (R_S + jX_S) \frac{P - jQ}{V} = \frac{R_S P + X_S Q}{V} + j \frac{X_S P - R_S Q}{V} = \Delta V_R + j \Delta V_X$$

ΔV depends on both real and reactive power of the load

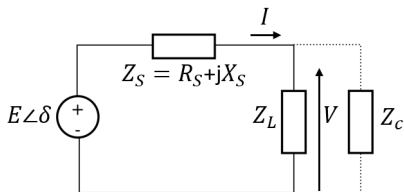

- Adding a compensator in parallel with the load, it is possible for $|E| = |V|$
- So, the total reactive power is $Q = Q_L + Q_C$. The value required for Q_C to achieve the 'constant voltage' condition is found by solving

$$|E|^2 = \left| V + \frac{R_S P + X_S Q}{V} \right|^2 + \left| \frac{X_S P - R_S Q}{V} \right|^2$$

2 Voltage correction by shunt capacitors or inductors

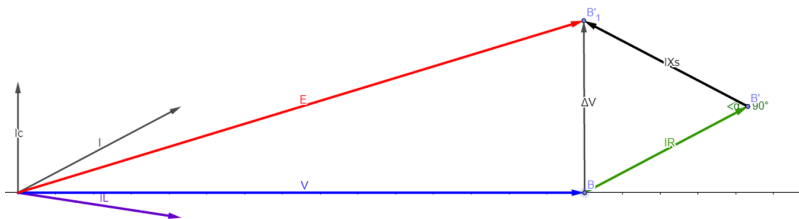
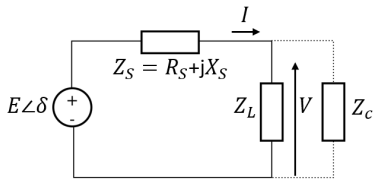

- This implies that a purely reactive compensator can eliminate voltage variations caused by changes in both active and reactive power of the load

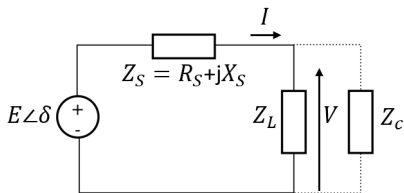

- At the same time, the compensator can be used to maintain unity power factor so that $Q = Q_L + Q_C = 0$. Leading to:

$$\Delta V = (R_S + jX_S) \frac{P}{V}$$

which is independent of Q and therefore not under the control of compensator!

A purely reactive compensator can NOT maintain both constant voltage and unity power factor at the same time!

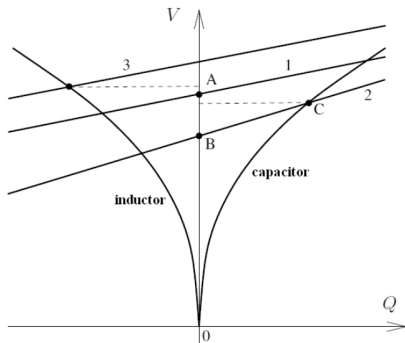
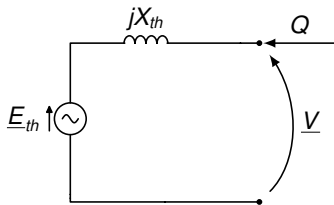

- Based on the previous analysis for the Thevenin equivalent and fault level

$$\frac{\Delta V}{V} = \frac{X_{th}Q}{V^2} \approx \frac{Q}{S_{SC}} \quad V \approx E_{th} \left(1 - \frac{Q}{S_{SC}} \right)$$

- The most economical way of correcting voltage deviations at a bus
- control:
 - manual: by operator from dispatch center
 - automatic: by a local controller measuring voltage, comparing to threshold value, and reacting after some delay
- this is an adjustment "in steps", not a fine tuned control
- repeated and/or fast switching not possible with the mechanical breakers
→ use power electronics components

3 Outline

1 Fundamentals

2 Static compensation

3 Synchronous machine

- Excitation systems of synchronous machines
- Response to a disturbance
- QV curves
- Underexcitation limiter

4 Synchronous condenser

5 FACTS devices

6 Load Tap Changers

7 Impact of renewables in LV systems

3.1 Components of control chain

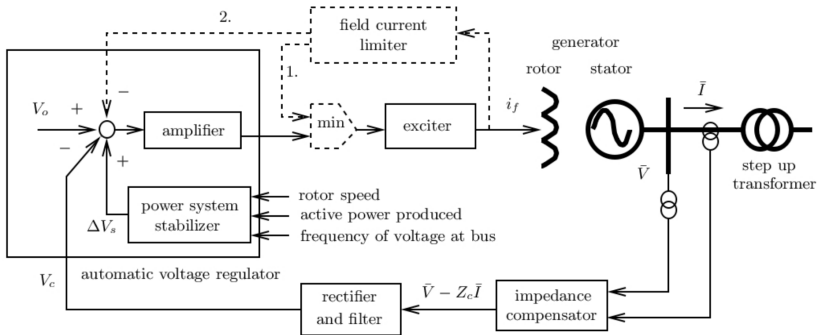

Exciter

- injects in the field winding a DC current under a DC voltage
- can quickly vary v_f and i_f in response to disturbances
- rotating (auxiliary) machine on the same shaft as generator: power $v_f i_f$ provided by turbine
 - in the past: Direct Current generator
 - nowadays: Alternating Current generator + rectifier
- "static" system: transformer + rectifier

Impedance compensator

- voltage drop in step-up transformer partly compensated
- voltage controlled at a fictitious point closer to the transmission network
 - typically $Z_c \simeq 50 - 90\%$ of the transformer series impedance
 - in what follows, it is assumed that $Z_c = 0$.

- In response to a large disturbance (typically a short-circuit), it is important to let the excitation system produce a high current i_f in order to support voltage
- in such circumstances, i_f may quickly rise up to a "ceiling" value $\simeq 2I_{fmax}$
 I_{fmax} : permanent admissible value
- such high value cannot be tolerated for more than a few seconds
- but milder field current overloads can be tolerated for longer ($\int i^2 dt$)
- inverse time characteristic:

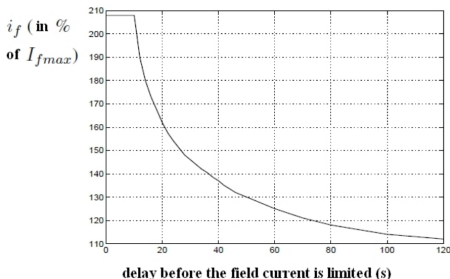

Two techniques to limit the field current:

- 1 control the exciter with: $\min(\text{AVR signal}, \text{OEL signal})$
main voltage control loop opened when limiter is active
- 2 inject in the main AVR summing junction a correction signal
 - zero as long as the limiter does not act
 - such that the field current is smoothly brought back to its limit
 - can be seen as an automatic reduction of the voltage setpoint V_o .

The voltage regulator regains control as soon as operating conditions permit.

Stator current limiter

- less widespread than rotor current limiter
- larger thermal inertia of stator \Rightarrow slower action, by power plant operator is enough
- two possibilities: decrease voltage setpoint V_o or generated active power P
- some generators are equipped with an automatic stator current limiter, acting on the exciter as the field current limiter does.

3.2 Simplifying assumptions

- round-rotor machine with synchronous reactance X
- saturation and stator resistance neglected
- constant active power production P (since we focus on V and Q)
- infinitely accurate voltage control: terminal voltage V constant in steady state.

What happens in the network:

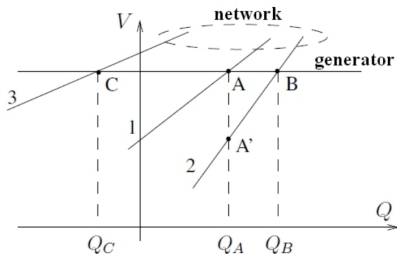

1 \rightarrow 2 : the generator produces more reactive power to keep its voltage constant

1 \rightarrow 3 : the generator produces less reactive power to keep its voltage constant

3.2 What happens in the voltage-controlled machine

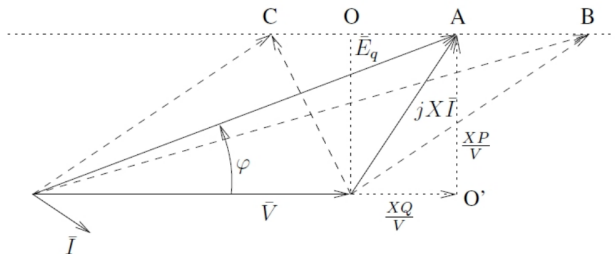

\bar{V} is constant

Q varies under constant $P \rightarrow$ the extremity of \bar{E}_q moves on a parallel to \bar{V} .

When the emf phasor \bar{E}_q ends up:

- at point O: zero reactive power
- to the right of point O: the generator operates in over-excitation mode
- to the left of point O: the generator operates in under-excitation mode

1 \rightarrow 2 : A \rightarrow B : Q , E_q and i_f increase

1 \rightarrow 3 : A \rightarrow C : Q , E_q and i_f decrease

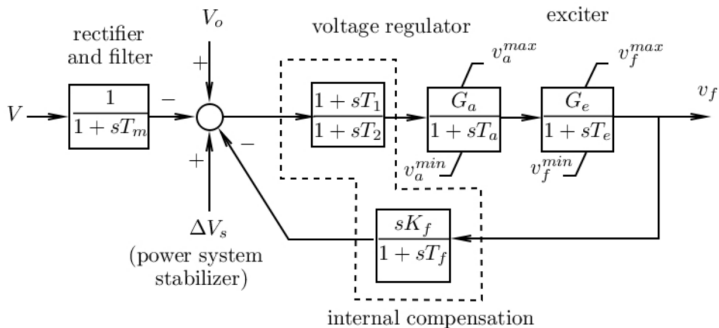

In steady state:

- $v_f = G_a G_e (V_o - V)$
- there must be a permanent error: $v_f \neq 0 \Rightarrow V \neq V_o$

In steady-state:

$$E_q = \frac{\omega_N L_{af}}{\sqrt{2}} i_f = \frac{\omega_N L_{af}}{\sqrt{2} R_f} v_f = \frac{\omega_N L_{af}}{\sqrt{2} R_f} G_a G_e (V_o - V)$$

Open-loop static gain¹:

$$G = G_a G_e \simeq 20 - 200 \text{ pu/pu}$$

The phasor diagram gives:

$$E_q^2 = \left(V + X \frac{Q}{V} \right)^2 + \left(X \frac{P}{V} \right)^2$$

The steady-state behaviour is obtained by substituting E_q in the two boxed equations.

¹smaller values usually observed in older systems

3.3 Example of QV characteristic

Machine with $X = 2.2$ pu

P and Q in pu on the machine
(voltage and power) base

For each (G, P) combination,
 V_o was adjusted to have
 $Q = 0$ when $V = 1$ pu

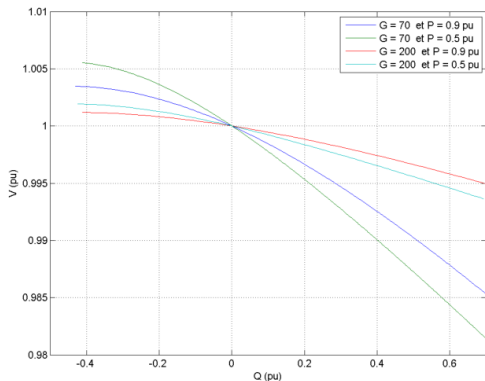

- The machine experiences a slight voltage drop as Q increases
 - slope of the curve larger if G is smaller
 - slope slightly influenced by the value of P
- steady-state error stems from proportional control

3.3 Simplified generic model of an excitation system: second type

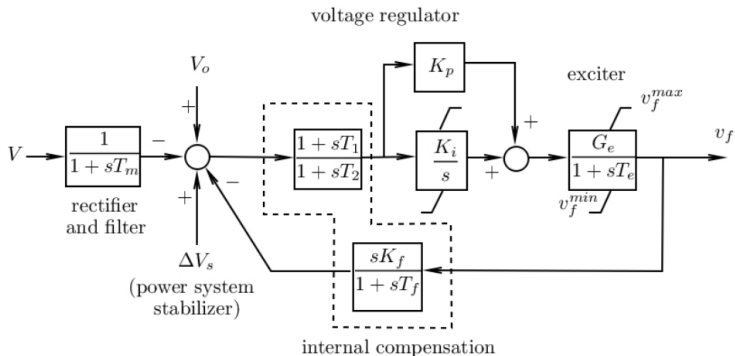

- PI control with $K_p, K_i > 0$
- In steady state: $V = V_0$
- no permanent regulation error (assumption made in previous section accurate for this excitation system)
- the QV curve is simply an horizontal line

3.3 Machine under rotor or stator current limit

Example:

nominal apparent power: 1200 MVA
turbine nominal power: 1020 MW

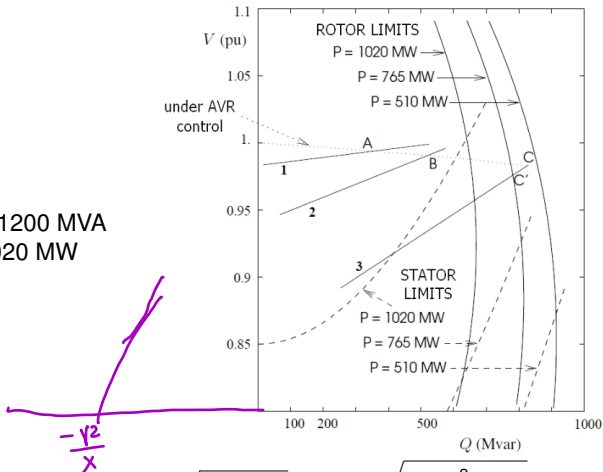

Under stator current limit: $S = VI_N = \sqrt{P^2 + Q^2} \Rightarrow Q = \sqrt{(VI_N)^2 - P^2}$

Extreme scenario: machine under limit \Rightarrow V drops a lot \Rightarrow generator tripped by undervoltage protection \Rightarrow productions P and Q lost!!

3.4 Underexcitation limiter

As the machine absorbs more and more reactive power:

- the extremity of the \vec{E}_q phasor moves to the left (N \rightarrow M \rightarrow L)
- E_q first decreases, then increases
- δ increases

At point M:

- $\delta = 90^\circ$
- excitation is minimum
- $E_q = E_q^{min} = \frac{XP}{V}$
- $X\frac{Q}{V} = -V \Leftrightarrow Q = -\frac{V^2}{X}$

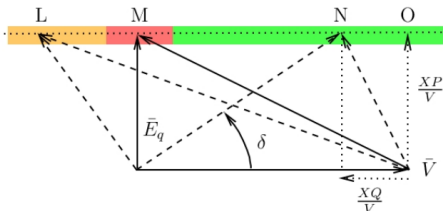

orange zone:

- \rightarrow unstable operation under constant excitation (constant E_q);
- \rightarrow stable operation under the control of the AVR;
- \rightarrow operation would become unstable if AVR had a failure!

red zone:

- \rightarrow if an excitation system failure makes E_q drop (even a little) below E_q^{min} ;
- \rightarrow the machine loses synchronism (torque T_e too small, due to low i_f);
- \rightarrow it is then tripped by the "loss of field" protection.

3.4 Underexcitation limiter

The underexcitation limiter:

- prevents operation to the left of, and in some neighbourhood of point M
- keeps a security margin with respect to M.

Capability curve corresponding to $\delta = \delta_{\max}$ (for instance 75°)?

$$\text{phasor diagram projected on } \bar{V} : E_q \cos \delta_{\max} = V + X \frac{Q}{V}$$

$$\text{phasor diagram projected on } \perp \bar{V} : E_q \sin \delta_{\max} = X \frac{P}{V}$$

$$\tan \delta_{\max} = \frac{X \frac{P}{V}}{V + X \frac{Q}{V}} = \frac{P}{\frac{V^2}{X} + Q} \quad \Leftrightarrow \quad P = \tan \delta_{\max} \left(Q + \frac{V^2}{X} \right)$$

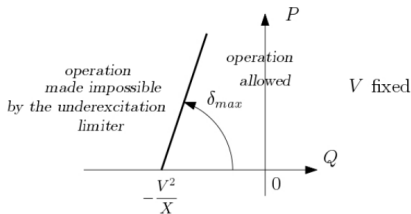

Acts on excitation system using the same techniques as for the OEL.

- 1 Fundamentals
- 2 Static compensation
- 3 Synchronous machine
- 4 **Synchronous condenser**
- 5 FACTS devices
- 6 Load Tap Changers
- 7 Impact of renewables in LV systems

~~synchr. machine~~

inertia
freq. conv.
voltage conv.

4 Synchronous condenser

Synchronous machine equipped with an automatic voltage regulator, used to control the voltage at one bus of the network

- produces or absorbs reactive power, as required by voltage control
- not driven by a turbine \Rightarrow does not produce active power
- consumes a small active power corresponding to Joule losses at the stator and mechanical friction of rotor
- still in use nowadays, but static var compensator² is often preferred.

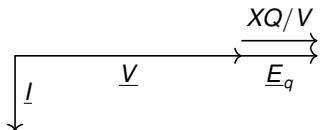

$$Q > 0$$

over-excitation mode

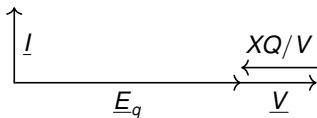

$$Q < 0$$

under-excitation mode

²next section

 Except from reactive power/voltage control, what else can the synchronous condenser be used for?

5 Outline

1 Fundamentals

2 Static compensation

3 Synchronous machine

4 Synchronous condenser

5 **FACTS devices**

- Thyristor-Controlled Inductor (TCI)
- Thyristor-Switched Capacitor (TSC)
- Static Var Compensator (SVC)
- STATCOM
- Dynamic Voltage Restorer
- UPFC

6 Load Tap Changers

7 Impact of renewables in LV systems

5 Shunt compensation principles

Main idea concerning shunt compensation:

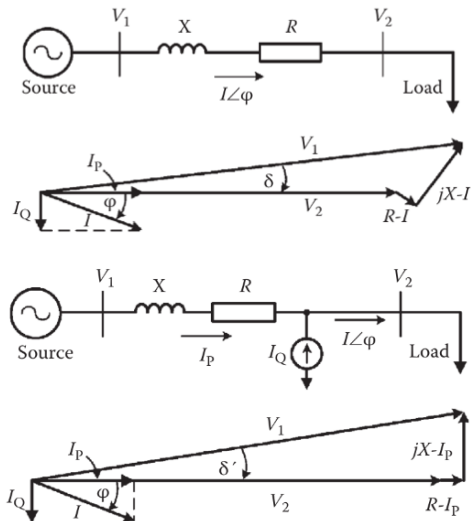

- Power electronics-based voltage compensators can provide quick responses to reactive power control. These can prevent voltage flickering caused by industrial loads (arc furnaces).
- Also, they provide dynamic voltage regulation to enhance stability of two interconnected ac systems.
- These controllers are grouped under the heading of FACTS (Flexible AC Transmission Systems), and they include primarily the following types of static VAR controllers:
 - The SVC, consisting of Thyristor-controlled inductor and thyristor controlled capacitor and their combined form.
 - The TCSC, thyristor-controlled series capacitor
 - STATCOM and DVR-switching converter with minimum energy storage elements.
 - UPFC-Unified power flow controller – combine STATCOM & DVR

Electronic component used as a switch

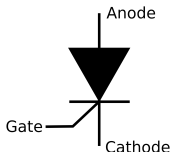

- current can flow if the anode voltage is higher than the cathode voltage ($v_A - v_C > 0$) and an impulse is applied to the gate (thyristor is "fired")
- current can flow from anode to cathode only (as in a diode): the thyristor blocks if the current attempts to change direction.

The gate impulses are produced by an electronic control system, independent of the power part but synchronized with the latter.

5.1 Thyristor-Controlled Inductor – TCI (or, Thyristor-Controlled Reactor – TCR)

- TCIs act as variable inductors where the inductive VARs supplied can be changed quickly.
- An inductor L is shunt connected to the AC source through a bidirectional switch consisting of two back-to-back thyristors.

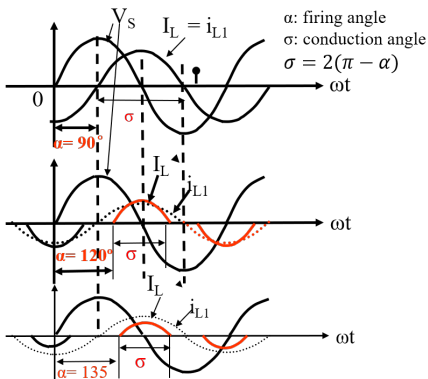
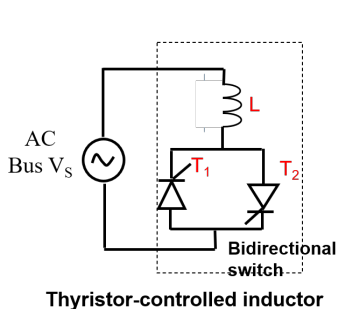

- If the phase angle α is varying in a range of 0 to 90° , TCI has no control over the current and its RMS value remains the same.
- If α is increased beyond 90° , I_{L1} is reduced, thus allowing a control of effective inductance value connected to the utility.
- The current through the inductor in steady state can be as a function of the thyristor delay angle, and equal value of delay angle is applied for both thyristors. Thus, TCI acts as variable inductors where the inductive VARS supplied can be varied very quickly.

The forward conduction non-sinusoidal pulses of current with the applied voltage are given by

$$\sqrt{2}V_S \sin \omega t = \omega L \frac{di}{d\omega t}$$

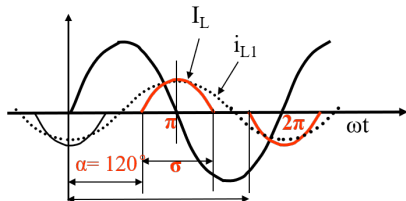

Integrating both sides between the limits α and $\alpha + \sigma$, the instantaneous current is given by

$$i = \begin{cases} \frac{\sqrt{2}V_S}{\omega L} (\cos \alpha - \cos \omega t) & \alpha < \omega t < \alpha + \sigma \\ 0 & \alpha + \sigma < \omega t < \alpha + \pi \end{cases}$$

The reverse instantaneous current

$$i = \begin{cases} \frac{\sqrt{2}V_S}{\omega L} (-\cos \alpha - \cos \omega t) & \pi + \alpha < \omega t < \pi + \alpha + \sigma \end{cases}$$

5.1 TCI current analysis

By Fourier analysis the fundamental current is

$$I_{L1(rms)} = \frac{V_S}{\pi\omega L} (2\pi - 2\alpha + \sin 2\alpha), \quad \frac{1}{2}\pi \leq \alpha \leq \pi, \quad \boxed{\sigma = 2\pi - 2\alpha}$$

$$I_{L1(rms)} = \frac{V_S \cdot (\sigma - \sin \sigma)}{\pi\omega L} = B_L(\sigma) V_S$$

The adjustable fundamental susceptance is

$$\boxed{B_L(\sigma) = \frac{(\sigma - \sin \sigma)}{\pi X_L} = \frac{1}{X_{TCI}}}$$

- $\sigma = \pi$ for full conduction in the thyristor controller

$$I_{L1(rms)} = \frac{V_S}{\pi\omega L}$$

- $\sigma = 0$ zero conduction in the thyristor controller

$$I_{L1(rms)} = 0$$

The reactive power drawn from the system is³:

$$Q = V_S I_{L1} = \frac{V_S^2}{\omega L_{eff}}$$

The effective inductance is:

$$L_{eff} = \frac{V_S}{\omega I_{L1}}$$

³For simplicity we stop using the "rms" subscript.

The TCI has to be controlled to determine the gating instants (and therefore σ) and issues gating pulses to the thyristors.

In some system B_L is determined directly. In others the control algorithm processes various measured parameters of the compensated system.

This results a V/I curve as shown in the figure

$$V_t = V_k + jX_S I_1 \quad 0 < I_1 < I_{\max}$$

I_{\max} is the rated current of the reactor

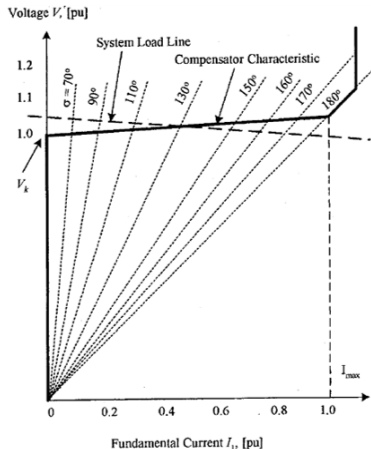

5.1 TCI harmonics

- The inductor current is not a pure sine wave when $\alpha > 90^\circ$. The rms value of the n -th harmonic components is given by

$$I_{Ln} = 4 \frac{V_S}{\pi \omega L} \left[\frac{\sin(\alpha + 1)\alpha}{2(n+1)} + \frac{\sin(n-1)\alpha}{a(n-1)} - \cos \alpha \frac{\sin n\alpha}{n} \right] \quad n = 3, 5, 7 \dots$$

- Connecting the three-phase TCI in **Delta** filters the harmonics of rank 3 (3, 9, ...).
- Capacitors connected in parallel to the TCI can filter out other high frequency harmonics (5, 7, ...).

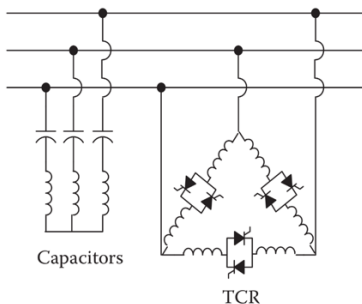

5.2 Thyristor-Switched Capacitor (TSC)

Principle:

- switch on/off a number of capacitors banks connected in parallel
- use thyristors as bidirectional switches.
- shunt compensation is varied in discrete steps
- no reaction as long as voltage remains in a deadband
- each capacitor can be switched at multiples of a half-period (10 ms at 50 Hz)

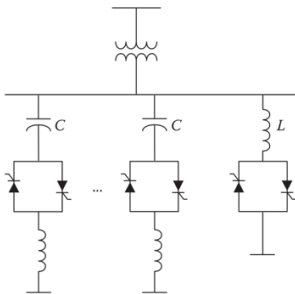

5.2 TSC operation

Unlike the phase angle control used in TCIs to vary the effective value of the inductor, TSCs employ **integral half-cycle control** where the capacitor is **either fully in or out** of the circuits.

$$I_C = \frac{V_S}{jX_C} = -j\omega C_{tot} V_S$$

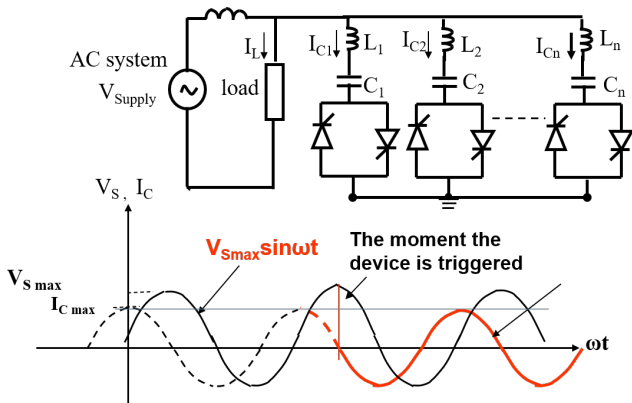

- The capacitor bank can be switched out by blocking the gate pulse to both thyristors. The current flow stops at the instant of zero crossing which also corresponds to the capacitor voltage equal to the maximum ac system voltage.
- The thyristor must be gated at the proper instant of the maximum ac voltage to avoid large over-currents.
- In principle the capacitor changing steps can be made as small and as numerous as desired by having a sufficient number of individually switched capacitors.

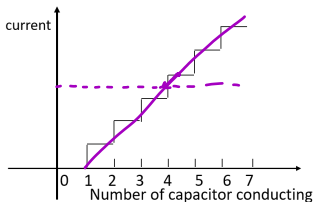

- Ignoring switching transient the current is sinusoidal at **steady state**, no harmonics.

5.3 Static Var Compensator (SVC)

- Combination of TSC and TCI forms a SVC having advantage of both elements → Produce **and** consume reactive power.
- The parameters are determined according to the compensation requirements of the system and the maximum reactive power Q_{SVC}

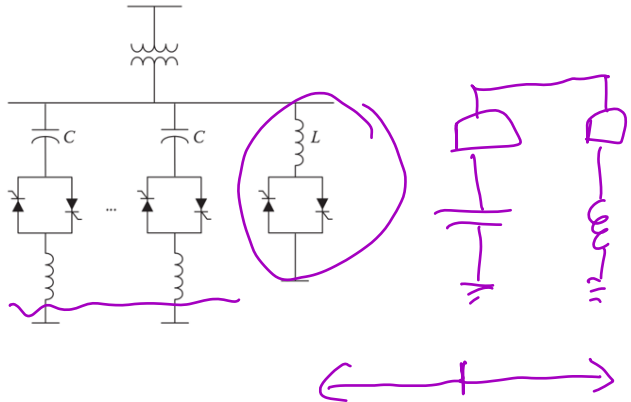

5.3 SVC operation

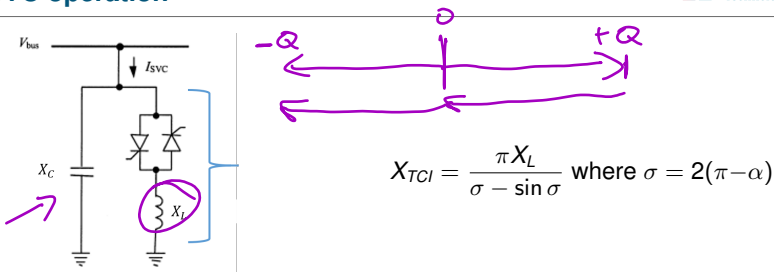

Total impedance:

$$Z_{SVC} = Z_C \parallel Z_{TCL} = \frac{Z_C Z_{TCL}}{Z_C + Z_{TCL}} = \frac{(-jX_C)(jX_{TCL})}{(-jX_C) + (jX_{TCL})} = \frac{(-jX_C) \left(j \frac{\pi X_L}{\sigma - \sin \sigma} \right)}{(-jX_C) + \left(j \frac{\pi X_L}{\sigma - \sin \sigma} \right)}$$

$$\Rightarrow Z_{SVC} = j \frac{\pi X_C X_L}{X_C(\sigma - \sin \sigma) - \pi X_L}$$

For symmetric operation:

$$X_C = \frac{V_{bus}^2}{Q_{SVC}}, \quad X_L = \frac{X_C}{2}$$

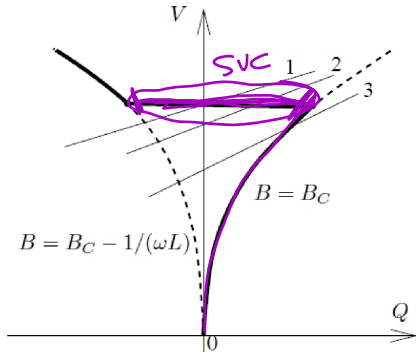

$$Q_c = \frac{V^2}{X_c}$$
$$X_c = \frac{V^2}{Q_c}$$

Adjustment of compensator operating point:

- Q is kept close to zero, to leave a reactive power reserve on the TCR, so that it is ready to counteract a disturbance in the network
- Q adjusted by switching on/off capacitors in parallel with the TCR
- mechanically: with breakers
- electronically: via a TSC

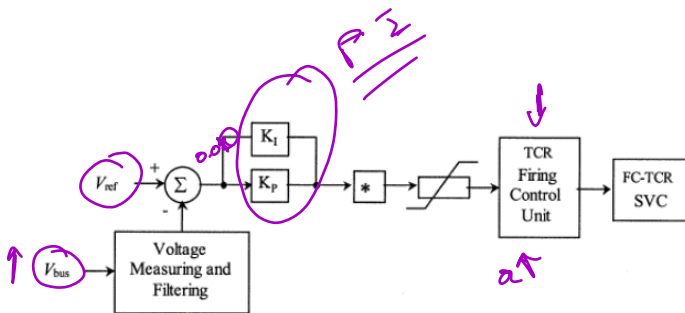

- SVC's ability for voltage regulation at the point of connection depends on the voltage closed-loop control scheme.

$\alpha = 90 \rightarrow \text{full } Q_L$
 $\alpha = 180 \rightarrow \text{zero } Q_L$

- The STATCOM is the static counter part of the rotating synchronous condenser, but it generates/absorbs reactive power at a faster rate because no moving part is involved.
- In principle it performs the same voltage regulation function as the Static Voltage Compensator, but in a more robust manner.
- It may be used for the dynamic compensation of power transmission systems providing voltage support and increased transient stability margins.

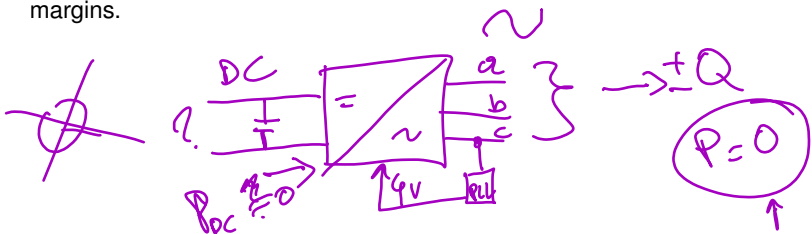

- The most basic configuration of a STATCOM consists of a two-level VSC with a DC energy storage device (battery or a capacitor), a coupling transformer connected in shunt with the AC system, and the associated control circuits)

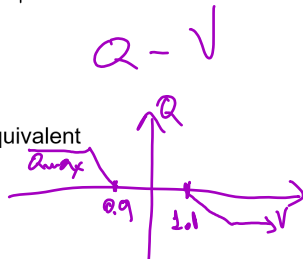
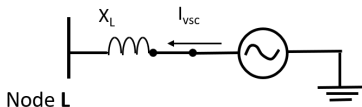
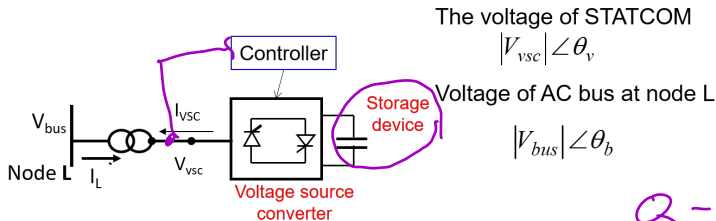

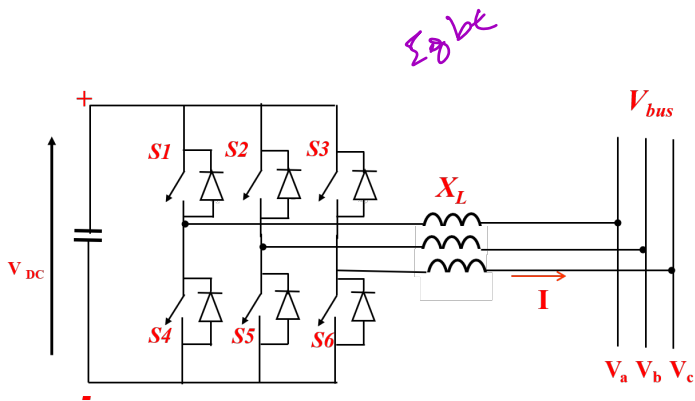

The reactive power exchange between STATCOM and AC system is given by

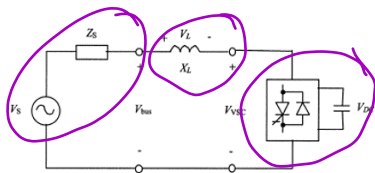

$$Q = \frac{|V_{bus}|^2}{X_L} - \frac{|V_{bus}| |V_{vsc}|}{X_L} \cdot \cos(\theta_b - \theta_v) = \frac{|V_{bus}|^2 - |V_{bus}| |V_{vsc}| \cos \delta}{X_L}$$

where $\delta = \theta_b - \theta_v$, and $\theta_b = \theta_v$ for the case of a lossless STATCOM

- If $|V_{bus}| > |V_{vsc}|$ then Q becomes positive and the STATCOM absorbs reactive power, otherwise, if $|V_{bus}| < |V_{vsc}|$ then Q becomes negative and the STATCOM generates reactive power.
- With suitable variation of the phase angle between V_{vsc} and V_{bus} , the STATCOM can exchange active power with the AC system.

$$P = \frac{V_{bus} V_{vsc}}{X_L} \sin \delta \quad \text{and } P = 0 \text{ when } \delta = 0$$

5.4 STATCOM operation

The following is the steady state vector representation at the fundamental frequency for capacitive and inductive modes, and for the transition states from capacitive to inductive and vice versa. The terminal voltage V_{bus} is equal to the sum of the inverter voltage V_{vsc} and the voltage across the coupling transformer reactance V_L in both capacitive and inductive modes.

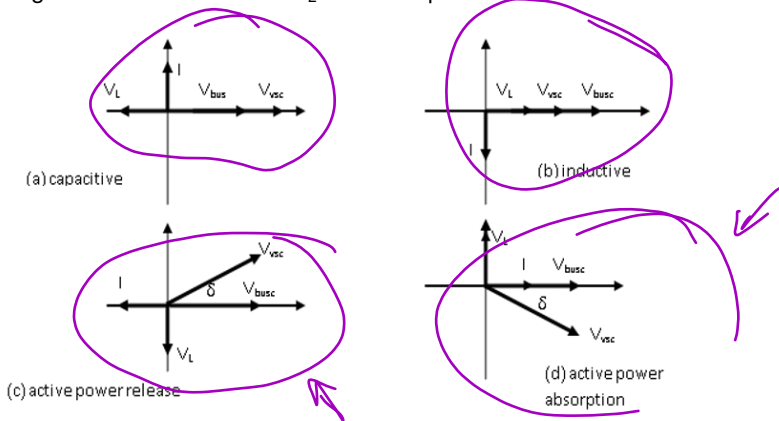

5.4 STATCOM operation

- From the above it is clear STATCOM can be controlled by a single parameter:
 - The magnitude of VSC voltage controls the reactive power flow between the STATCOM and AC bus.
 - The phase angle of VSC output voltage controls the active power flow, though a STATCOM is not used for absorbing or supplying real power.
- In any practical STATCOM there are losses in the transformer windings and in the converter switches. These losses consume active power from the AC terminals.
- A small phase shift always exists between the VSC voltage and the AC system voltage to boost the DC voltage.
- STATCOMs are used in both transmission (FACTS controller) and distribution systems (Custom Power controller) for reactive power compensation and voltage regulation.
- In low-to-medium voltage Compensation application, VSC in STATCOM uses PWM control to suppress harmonics and control the DC to AC voltage ratio.
- However, at high voltage for FACTS application the high ratings of the converter will require valves of high power rating, dictating slow switching speed and increased switching losses, so PWM may not be used.

5.4 STATCOM controller

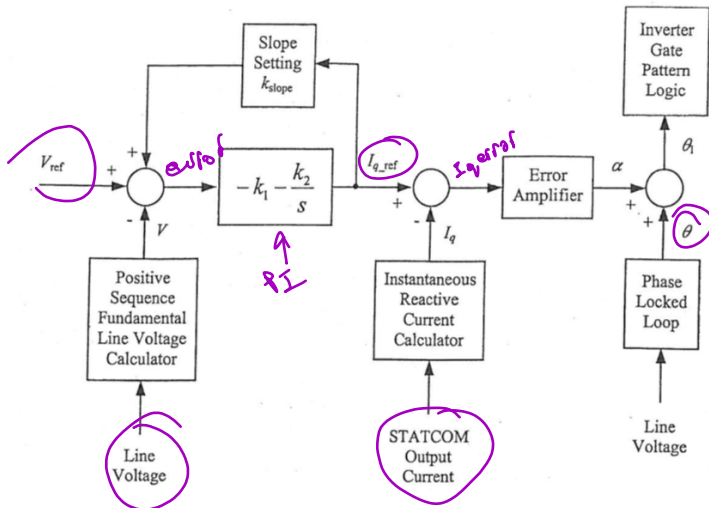

5.4 Comparison of basic types of shunt compensators

	Synchronous Condenser	Static Compensator		
		TCR (with Shunt Capacitors if Necessary)	TSC (with TCR if Necessary)	Self-Commutated Compensator
Accuracy of compensation	Good	Very good	Good, very good with TCR	Excellent
Control flexibility	Good	Very good	Good, very good with TCR	Excellent
Reactive power capability	Leading/lagging	Lagging/leading indirect	Leading/lagging indirect	Leading/lagging
Control	Continuous	Continuous	Discontinuous (continuous with TCR)	Continuous
Response time	Slow	Fast, 0.5 to 2 cycles	Fast, 0.5 to 2 cycles	Very fast but depends on the control system and switching frequency
Harmonics	Very good	Very high (large-size filters are needed)	Good, filters are necessary with TCR	Good, but depends on switching pattern
Losses	Moderate	Good, but increase in lagging mode	Good, but increase in leading mode	Very good, but increase with switching frequency
Phase balancing ability	Limited	Good	Limited	Very good with 1- ϕ units, limited with 3- ϕ units
Cost	High	Moderate	Moderate	Low to moderate

Source: Power Systems, 3rd edition, L. L. Grigsby

5.5 Series compensation principles

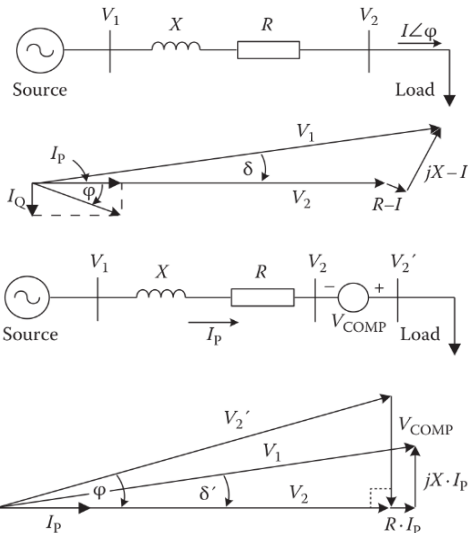

This is another power converter-based device used in the power systems. It is to control

- voltage sags and swells
- voltage unbalance
- voltage harmonics
- power factor correction

The DVR injects a set of three-phase AC voltages in series and synchronized with the distribution voltage of the AC system. The amplitude and phase angle of the injected voltage are variable thereby allowing control of the active and reactive power exchange between DVR and the AC system within predetermined positive(power supply) and negative (power absorption) limits.

A VSC is series connected in power line through a transformer, it is used to alleviate a range of dynamic power quality problems.

Current through DVR transformer primary is:

$$\frac{|V_{tl}| \angle \theta_{tl} - |V_{tm}| \angle \theta_{tm} - |V_{cR}| \angle \theta_{cR}}{X_{cR}} = I_{cR}$$

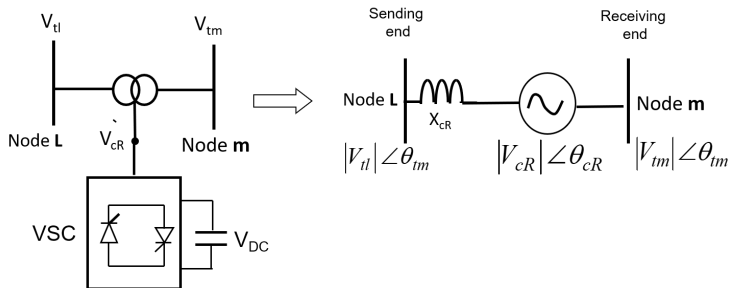

5.5 DVR operation

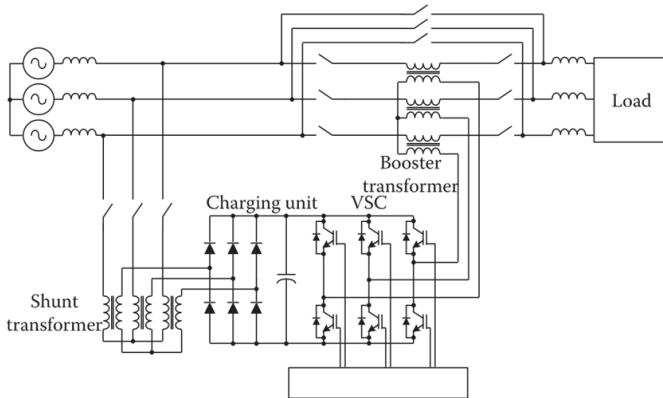

Source: Power Systems, 3rd edition, L. L. Grigsby

Active and reactive powers delivered to the receiving terminal tm assuming ($R \approx 0$) are

$$P_{tm} \approx \frac{V_t V_{tm}}{X} \sin \delta$$

$$Q_{tm} \approx \frac{V_{tm}}{X} (V_{tl} \cos \delta - V_{tm})$$

Active and reactive powers leaving the sending terminal tl are

$$P_{tl} \approx \frac{V_{tl} V_{tm}}{X} \sin \delta$$

$$Q_{tl} \approx \frac{V_t}{X} (V_{tl} - V_{tm} \cos \delta)$$

Active and reactive powers can be controlled by adjusting

- Voltage magnitudes V_{tl} , V_{tm} at both ends of the line,
- the power angle δ , which is the difference between the terminal voltage angles,
- the series reactance X of the line.

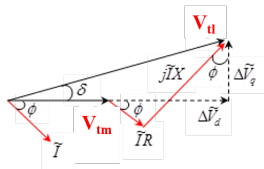
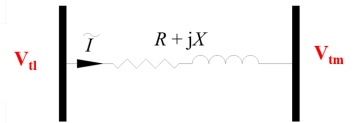

5.6 Unified Power Flow Controller (UPFC)

- The UPFC may be seen to consist of one STATCOM and one DVR sharing a common capacitor on their DC side and a unified control system.
- The active power demanded by the series converter is drawn by the shunt converter from the AC network and supplied via the DC link. The inverter voltage of the series converter is added to the nodal voltage, at say node l , to boost the nodal voltage at node m .

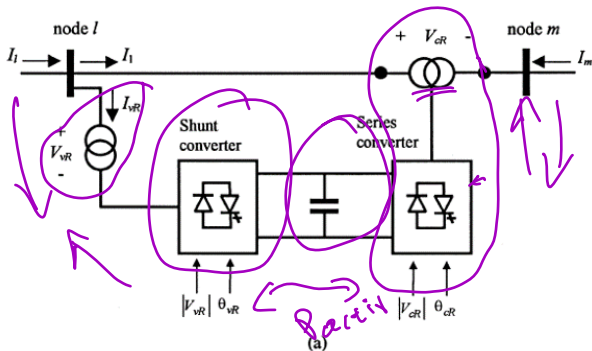

- The voltage magnitude of the inverted voltage $|V_{cR}|$ provided voltage regulation and the phase angle θ_{cR} determines the mode of power flow control.

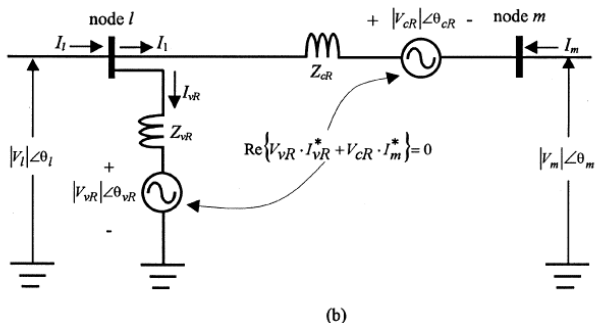

- If θ_{cR} is in phase with the voltage phase angle θ_I , it regulates no active power flow.
- If θ_{cR} is in quadrature with the voltage phase angle θ_I it controls active power flow performing as a phase shifter but drawing no reactive power from the AC network.
- If θ_{cR} is in quadrature with the current phase angle then it controls active power flow performing as a variable series impedance compensator.
- At any other value of θ_{cR} , it performs as a combination of a phase shifter and a variable series impedance compensator. This is in addition to being a voltage regulator by suitable control of $|V_{cR}|$

- UPFC shunt converter may also control reactive power in order to provide independent voltage magnitude regulation at its point of connection with the AC system voltage.
- An active power constraint equation which links the two voltage sources

$$\begin{aligned} V_{vR} &= |V_{vR}| (\cos \theta_{vR} + j \sin \theta_{vR}) \\ V_{cR} &= |V_{cR}| (\cos \theta_{cR} + j \sin \theta_{cR}), \end{aligned} \quad \text{Re} \{-V_{vR} I_{vR}^* + V_{cR} I_m^*\} = 0$$
$$V_{vR \min} \leq V_{vR} \leq V_{vR \max} \quad \text{and} \quad 0 \leq \theta_{vR} \leq 2\pi$$
$$V_{cR \min} \leq V_{cR} \leq V_{cR \max} \quad \text{and} \quad 0 \leq \theta_{cR} \leq 2\pi$$

- 1 Fundamentals
- 2 Static compensation
- 3 Synchronous machine
- 4 Synchronous condenser
- 5 FACTS devices
- 6 Load Tap Changers**
- 7 Impact of renewables in LV systems

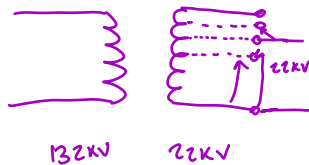

$$C = \frac{132}{27} \quad C' = \frac{132}{23}$$

$$V_1 = V_2 \cdot C$$

$$V_2 = \frac{V_1}{C} < V_2' = \frac{V_1}{C'}$$

- widely used to control voltages in networks of lower nominal voltage
 - HV sub-transmission and MV distribution networks
 - where no longer power plants are connected (replaced by more powerful ones connected to transmission network)
 - to compensate for voltage deviations in the EHV transmission network and serve the end consumers under correct voltage
- main way of controlling voltages in MV distribution grids. Other ways available at distribution level:
 - switch on/off shunt capacitors (but this is mainly for power factor correction)
 - adjust the active and/or reactive production of distributed generation units
 - not much used yet, but
 - likely to be required in the future, with the expected deployment of renewable energy sources

6 Automatic load tap changer

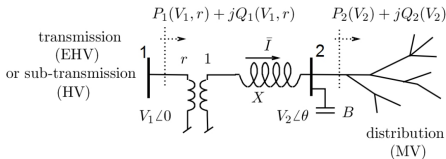

$$r \simeq 85-90 \text{ to } 110-115 \%$$

$$\Delta r \simeq 0.5 - 1.5 \%$$

$$\Delta r < 2\epsilon$$

Automatic load tap changer: adjusts r to keep V_2 into the deadband:

$$[V_2^o - \epsilon V_2^o + \epsilon]$$

$$1.01 - 0.99$$

Voltage setpoint V_2^o

- standard MV distribution systems "importing" active power:
 - V_2^o higher than nominal voltage to counteract the voltage drop in MV grid
 - in some cases, the tap changer controls a "downstream" voltage $|\bar{V}_2 - Z_c \bar{I}|$

\bar{I} : see figure Z_c : compensation impedance

- MV distribution systems hosting distributed generation sources and "exporting" active power:
 - V_2^o lower than nominal voltage to avoid overvoltages at MV buses

Load tap changers are rather slow devices.

Delay between two tap changes:

- minimum delay T_m of mechanical origin $\simeq 5$ seconds
- intentional additional delay: from a few seconds up to 1 – 2 minutes
 - to let network transients die out before reacting (avoid unnecessary wear)
 - fixed or variable
 - e.g. inverse-time characteristic: the larger the deviation $|V_2 - V_2^o|$, the faster the reaction
 - delay before first tap change ($\simeq 30 - 60$ seconds) usually larger than delay between subsequent tap changes ($\simeq 10$ seconds)
- if several levels of tap changers in cascade: the higher the voltage level, the faster the reaction (otherwise risk of oscillations between tap changers)

6 Behaviour of a distribution network controlled by a load tap changer

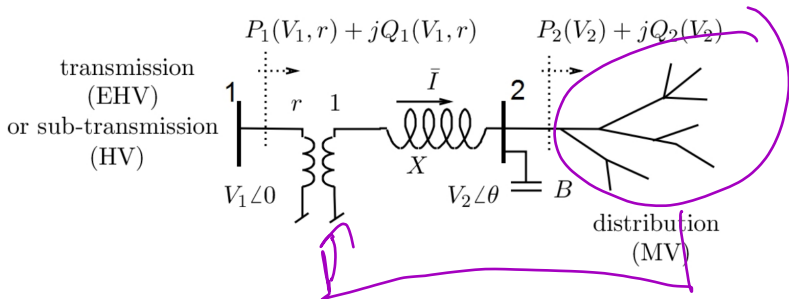

Assume the load is represented by the exponential model:

$$P_2(V_2) = P^o \left(\frac{V_2}{V_2^o} \right)^\alpha \quad Q_2(V_2) = Q^o \left(\frac{V_2}{V_2^o} \right)^\beta$$

$$Z = R + jX$$

For simplicity, the reference voltage V_2^o is taken equal to the LTC set-point.

$$\alpha = \beta = 2$$

$$P = \frac{V_2^2}{R} \quad Q = \frac{V_2^2}{X}$$

- The power balance equations at bus 2 are:

$$P^o \left(\frac{V_2}{V_2^o} \right)^\alpha = -\frac{V_1 V_2}{rX} \sin \theta$$

$$Q^o \left(\frac{V_2}{V_2^o} \right)^\beta - BV_2^2 = -\frac{V_2^2}{X} + \frac{V_1 V_2}{rX} \cos \theta$$

- For given values of V_1 and r , the Eqs. can be solved numerically with respect to θ and V_2 (using Newton method for instance)
- from which the power leaving the transmission network is obtained as:

$$P_1 = -\frac{V_1 V_2}{rX} \sin \theta \quad (= P_2) \quad Q_1 = \frac{V_1^2}{r^2 X} - \frac{V_1 V_2}{rX} \cos \theta$$

- repeating this operation for various values of V_1 and r yields the curves shown on the next slides.

Data:

- transformer: 30MVA, $X = 0.14\text{pu}$, $V_2^o = 1\text{pu}$
- load: $\alpha = 1.5$, $\beta = 2.4$, $P_2 = 20\text{ MW}$ under $V_2 = 1\text{ pu}$,
 $\cos \phi_u = 0.90$ (lagging) under $V_2 = 1\text{ pu}$
- with the compensation capacitor: $\cos \phi_c = 0.96$ (lagging) under
 $V_2 = 1\text{ pu}$

On the $S_B = 100\text{ MVA}$ base: $X = 0.14(100/30) = 0.467\text{ pu}$

$$V_2^o = 1\text{ pu} \quad P^o = 0.20\text{ pu} \quad Q^o = P^o \tan \phi_u = 0.20 \times 0.4843 = 0.097\text{ pu}$$

$$B \times 1^2 = Q^o - P^o \tan \phi_c \Rightarrow B = 0.097 - 0.20 \times 0.2917 = 0.039\text{ pu}$$

6 Numerical example

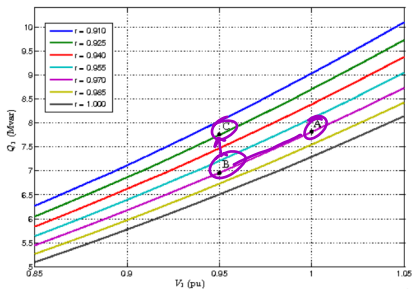
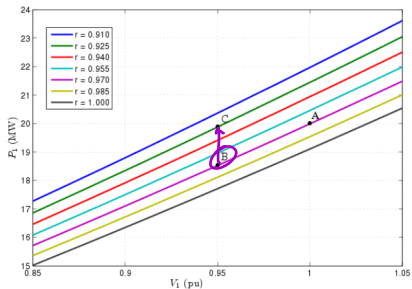
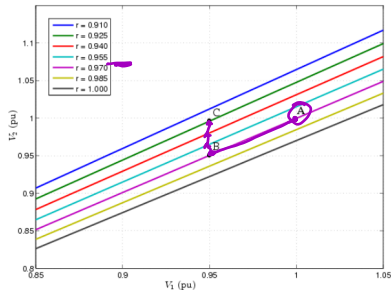

Initial operating point: A, where $V_1 = 1\text{pu}$, $r = 0.97\text{pu/pu}$, and $V_2 = V_2^o = 1\text{pu}$

Response to a 0.05 pu drop of voltage V_1 :

- in the short term, r does not change; the oper. point changes from A to B
- at point B, $V_2 < V_2^o - \epsilon = 0.99\text{pu}$
- hence, the LTC makes the ratio decrease by three positions, until $V_2 > V_2^o - \epsilon$
- and the operating point changes from B to C.

Neglecting the deadband 2ϵ :

- the V_2 voltage is restored to the setpoint value V_2^0
- hence, the P_2 and Q_2 powers are restored to their pre-disturbance values
- the same holds true for the P_1 and Q_1 powers. This was to be expected since:

$$P_1 = P_2 (V_2)$$

$$Q_1 = Q_2 (V_2) - BV_2^2 + XI_2^2 = Q_2 (V_2) - BV_2^2 + X \frac{P_2^2 (V_2) + Q_2^2 (V_2)}{V_2^2}$$

- hence, the load seen by the transmission system behaves in the long-term (i.e. after the tap changer has acted) as a constant power.
- This is true as long as the tap changer does not hit a limit.

- 1 Fundamentals
- 2 Static compensation
- 3 Synchronous machine
- 4 Synchronous condenser
- 5 FACTS devices
- 6 Load Tap Changers
- 7 Impact of renewables in LV systems**

7 Impact of renewables in LV systems

From slide 9, we have:

$$\Delta V = \frac{R_s P + X_s Q}{V} + j \frac{X_s P - R_s Q}{V}$$

Assuming injected active power (not consumed) at unit power factor, the voltage **rises** by:

$$\Delta V = \frac{R_s P + j X_s P}{V} < 0$$

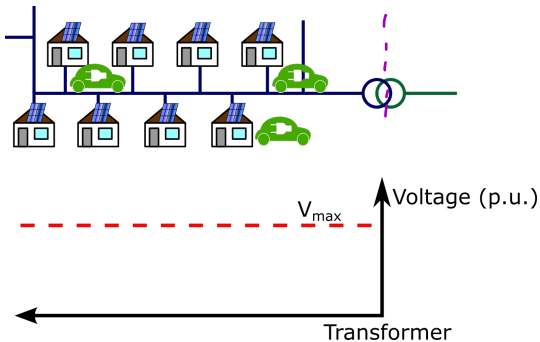

7 Impact of renewables in LV systems

From slide 9, we have:

$$\Delta V = \frac{R_s P + X_s Q}{V} + j \frac{X_s P - R_s Q}{V}$$

Assuming injected active power (not consumed) at unit power factor, the voltage **rises** by:

$$\Delta V = \frac{R_s P + j X_s P}{V} < 0$$

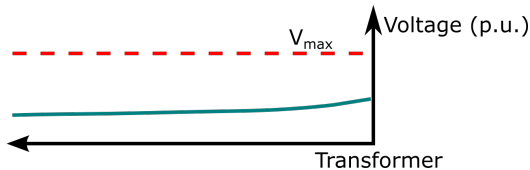
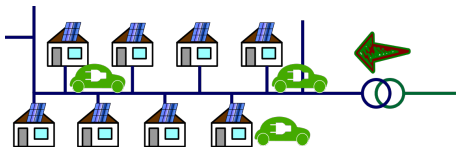

$$\Delta V > 0$$

7 Impact of renewables in LV systems

From slide 9, we have:

$$\Delta V = \frac{R_s P + X_s Q}{V} + j \frac{X_s P - R_s Q}{V}$$

Assuming injected active power (not consumed) at unit power factor, the voltage **rises** by:

$$\Delta V = \frac{R_s P + j X_s P}{V} < 0$$

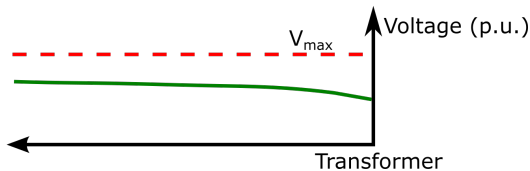
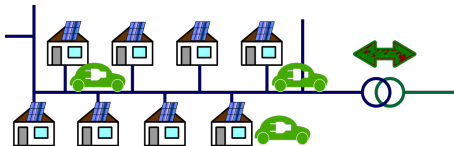

$$\Delta V \approx 0$$

7 Impact of renewables in LV systems

From slide 9, we have:

$$\Delta V = \frac{R_s P + X_s Q}{V} + j \frac{X_s P - R_s Q}{V}$$

Assuming injected active power (not consumed) at unit power factor, the voltage **rises** by:

$$\Delta V = \frac{R_s P + j X_s P}{V} < 0$$

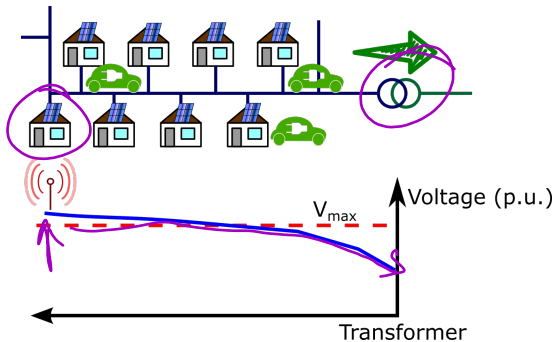

$$\Delta V < 0$$

7 Simple decentralized solutions

Have the RES units that create the problem to solve the problem. E.g.,

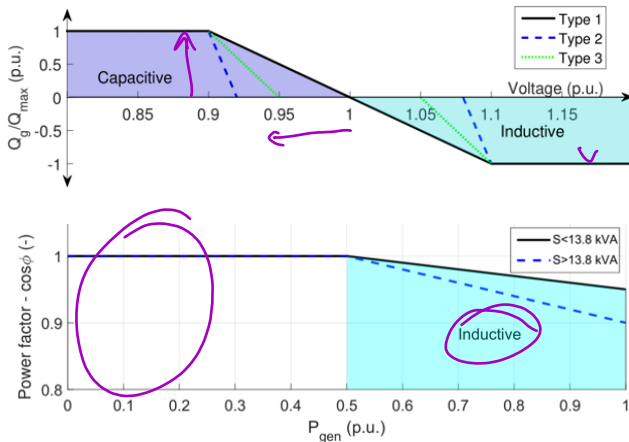

Source: VDE-AR-N 4105

Advanced, communication-based control with optimal performance. E.g.,

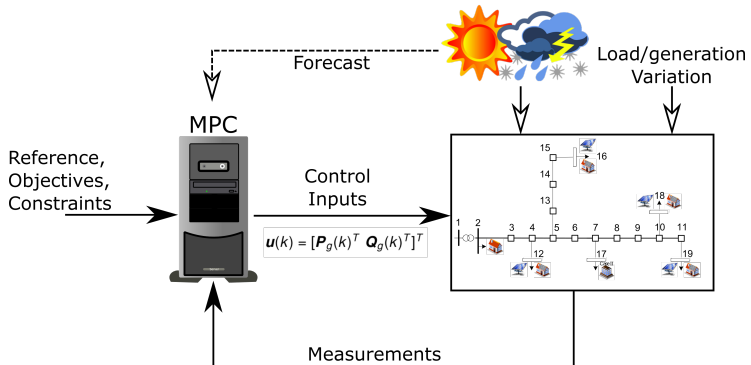

Source: Contribution of Distribution Network Control to Voltage Stability: A Case Study,
<https://sps.cut.ac.cy/publication/2017jaristidou/>